

Installation guide

Pressure operated water valve

WVFX 10 – WVFX 25 and WVO 10 – WVO 25

003R9743

003R9743

Refrigerants:

R22, R1270, R134a, R290, R404A, R407A, R407C, R407F, R410A*, R448A, R449A, R450A, R452A, R507A, R513A, R600, R600a, R717**

For complete list of approved refrigerants, visit www.products.danfoss.com and search for individual code numbers, where refrigerants are listed as part of technical data.

* High pressure refrigerants version (45,2 MWP) only

** WVFX 10 – WVFX 25 and WVO 10 – WVO 25 with flare connection only; versions with capillary tube or with solder connections are not compatible with R717.

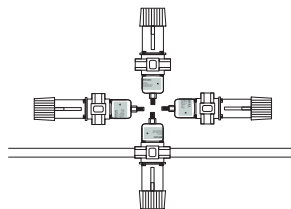
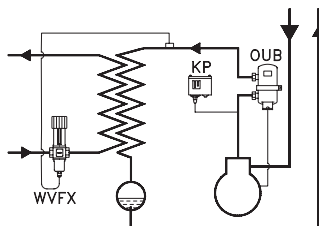
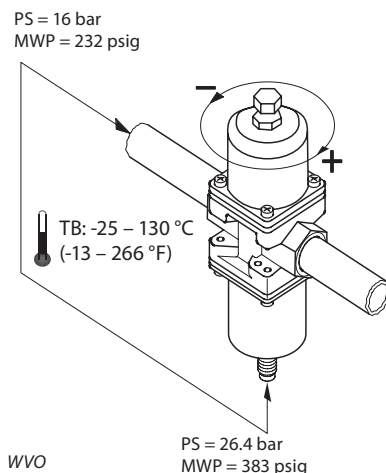
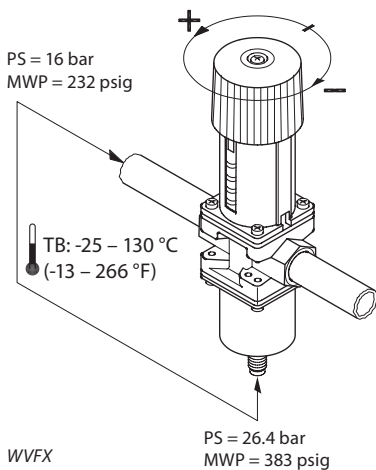

* only WVFX valves

