

Data Sheet

# Pilot-operated servo valve Type **ICS**

Controlling pressure, temperature and ON/OFF in refrigeration systems



ICS pilot-operated servo valves belong to the ICV (Industrial Control Valve) family.

The valve comprises three main components: valve body, function module and top cover.

ICS pilot-operated servo valves are pilot operated valves for regulating pressure, temperature and ON/OFF function in refrigeration systems. ICS valves are designed for low and high-pressure refrigerants.

ICS valves can be used on the high and lowpressure sides, in wet and dry suction lines and in liquid lines without phase change (i.e. where no expansion takes place in the valve).

The function of ICS valves is dependent on the pilot pressure applied from either a pilot valve or external pilot pressure source.

ICS 1 pilot has one pilot pressure connection and ICS 3 pilot has three pilot pressure connections.

**ЮГОВ - Проект**  
інженерно-виробниче підприємство

офіційний дистриб'ютор  
Danfoss в Україні

[ugov.ua](http://ugov.ua)

## Features

- Designed for industrial refrigeration applications for a maximum working pressure of 52 bar / 754 psig.
- Applicable to HCFC, HFC, R717 (Ammonia) and R744 (CO<sub>2</sub>).
- Direct coupled connections.
- Connection types include butt weld, socket weld, solder and threaded connections.
- Low temperature steel body.
- Low weight and compact design.
- V-port regulating cone ensures optimum regulating accuracy particularly at part load.
- Function module has a QPQ surface treated insert and a steel piston ring ensuring precise control accuracy.
- ICV 4 in., 5 in. and 6 in. ANSI with NPT threaded pressure outlet in the outlet of the valve.
- Replaceable Teflon valve seat for ICS 25-80.
- Maintenance spare part kit available for ICS 100-150.
- Modular Concept:
  - Each valve body is available with several different connection types and sizes.
  - Valve overhaul on ICS 25-80 is done by replacing the function module.
  - Possible to convert ICS pilot-operated servo valve to ICM motor operated valve.
- Manual opening.
- The ICS valve is a multifunction valve where several pilot valves can be mounted into the pilot ports.
- The standard range of pilot valves can be used on all sizes of ICS valves. Pilot valves can be either screwed directly into the ICS valve, thus eliminating the need for solder/weld connections or external pilot lines.
- Pressure gauge connection port to measure valve inlet pressure.
- The top cover can be rotated into any possible position without affecting the operation of the valve.
- To get an updated list of certification on the products please contact your local Danfoss Sales Company.

**Functions**

Figure 1: ICS 1 Pilot

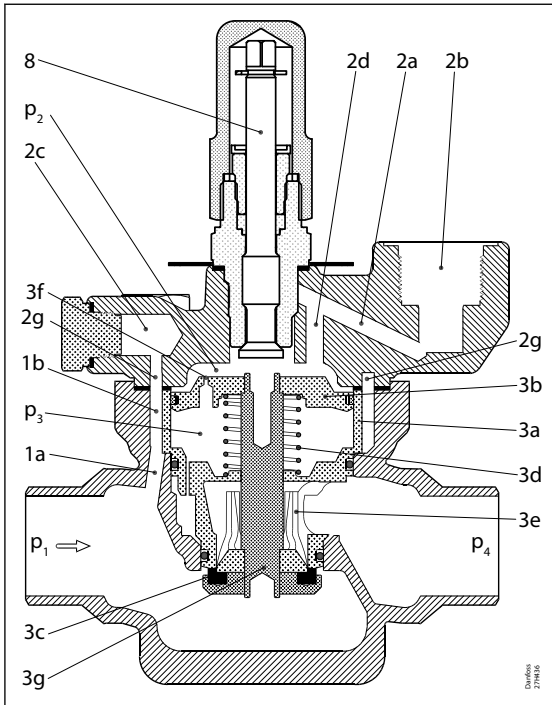
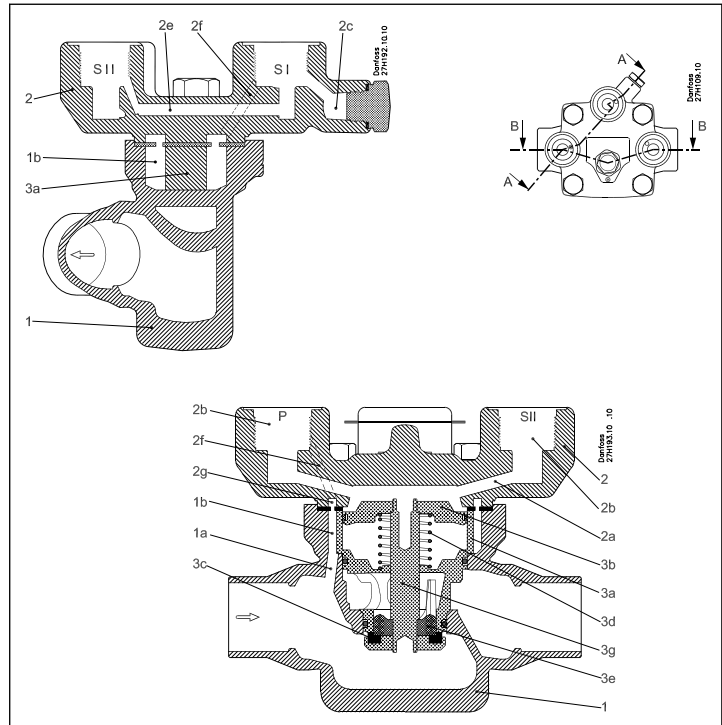

Figure 2: ICS 3 Pilots



**ICS 1 Pilot and ICS 3 Pilot**

1	Body	3a	Cylinder
1a	Pilot channel to inlet side	3b	Piston
1b	Circular gap between house and module	3c	Valve plate
2	Top cover	3d	Spring
2a	Pilot channels in top cover	3e	Cone
2b	Pilot insertion hole	3f	Equalisation orifice
2c	Pressure gauge connection	3g	Piston rod
2d	Piston top inlet channel	p <sub>1</sub>	Inlet pressure
2e	Cross channel S I to S II	p <sub>2</sub>	Pressure on piston
2f	Inlet channel	p <sub>3</sub>	Pressure underneath piston
2g	Circular groove	p <sub>4</sub>	Outlet pressure
3	Function module	8	Manual operating spindle

The ICS main valve is a pilot operated valve. The types of pilot valves used determine the function. The ICS main valve with pilot valve(s) controls refrigerant flow by modulation or on/off in accordance with the pilot valve and main valve status. The manual spindle can be used to open the valve plate.

The opening degree of the main valve is determined by the pressure difference (differential pressure) between pressure  $p_2$ , which acts on top of the servo piston (3b), and pressure  $p_3$ , which acts on the underside of the servo piston.

If this pressure difference is 0, the main valve will be fully closed.

## Pilot-operated servo valve, type ICS

If the pressure difference is 0.2 bar (3 psi) or greater, the main valve will be fully open. At pressure differences ( $p_2 - p_3$ ) between 0.07 bar (1 psi) and 0.2 bar (3 psi), the degree of opening will be correspondingly proportional.

The port of the throttle cone (3e) is V-shaped, which provide good regulation characteristic to pilot operated main valves even at low loads.  $P_3$  pressure is equal to the valve outlet pressure ( $P_4$ ), due to a clearance between the piston rod (3g) and the function module. The opening degree of the ICS valve is therefore controlled by the application of  $P_2$  pressure acting on top of the servo piston, which is equal to or greater than valve outlet pressure ( $P_4$ ).

$p_2 = p_4$  ~ closed

$p_2 = p_4 + 0.2$  bar (3 psi) ~ fully open

$p_4 \leq p_2 \leq p_4 + 0.2$  bar (3 psi) ~ proportional degree of opening.

The maximum pressure ( $p_2$ ) can act on the top of the servo piston (3b).  $p_2$  normally corresponds to the pressure,  $p_1$  - ICS main valve inlet pressure. Inlet pressure  $p_1$  is led, via the drilled channels (1a, 1b, 2f, 2b (pilot), 2a, 2d) in the valve body (1) and cover (2) through the individual pilot valves and onto the top of the servo piston (3b).

The degree of opening of the individual pilot valves determines the magnitude of pressure  $p_2$  and thus the degree of opening of the main valve. The equalisation hole (3f) in the servo piston (3b) ensures that pressure  $p_2$  is balanced in accordance with the degree of opening of the pilot valve.

### **NOTE:**

When ICS valves with 3 pilot ports are used with external pressure connector (Figure 2: ICS 3 Pilots, pos. 61), the valve port inlet pressure will be isolated.

The ICS can be fitted with just a single screwed-in pilot valve or external pilot connection. The degree of opening of the main valve will be in accordance with the control status of the pilot valve or external pilot flow control.

ICS main valve with one pilot connection is fully closed when the pilot valve is fully closed and fully open when the pilot valve is fully open. Otherwise the degree of opening of the main valve is proportional to the degree of opening of the pilot valve.

The ICS 3 pilot version can be fitted with one, two, or three pilot valves so that up to three regulating functions are possible. If the external pilot connection is used, more functions can be added.

In the ICS three pilot version, the pilot ports are related as follows:

- The pilot valves fitted in ports SI and SII are connected in series.
- The ICS 3 pilot operated main valve will be fully closed if just one of the series-connected pilot valves is closed. The main valve can only open if both pilot valves are open at the same time.
- The pilot valve fitted in port P is connected in parallel to the pilot valves in ports SI and SII.

The ICS valve will be fully open if the pilot valve in P is fully open, irrespective of the degree of opening of pilot valves SI and SII.

The ICS valve will be fully closed if the pilot valve in P is fully closed and at least one of the valves in SI or SII is fully closed at the same time. The relation between the pilot valves in ports SI, SII and P is shown in the table on the next page.

If the ICS is not fitted with three pilot valves, the unused port(s) must be sealed with a blanking plug. If the blanking plug is fitted as an assembled unit, A + B, the channels from the specific port will be closed. (See illustration below)

If only the top part, A, of the plug is fitted, the channels from the ports in question will be open. If the degree of opening of the ICS main valve is not to be a function of the main valve inlet pressure, or if more than three regulating functions are required, ports SI, SII or P can be fitted with a nipple for the connection of external pilot pressure. This applies to all ICS versions.

The pressure to which the external pilot line is connected will then determine pressure  $p_2$  on top of the servo piston. The pilot valves fitted in that external pilot line will determine the main valve function. Pilot valves installed in external lines must be mounted in a type CVH housing.

Depending on the function of the pilot valves, the ICS regulating characteristic becomes:

## Pilot-operated servo valve, type ICS

- on/off
- proportional
- integral or
- cascade.

ICS main valves are therefore especially suitable for all forms of temperature and pressure regulating systems.

An overview of the types of pilot valves available can be found in the literature "Pilot valves for operated main valves" (AI248786497190).

On the following pages, a number of configuration examples can be found. These are only for explanatory purpose. However, by using the literature regarding pilot valves these examples are easier to comprehend.

**Table 1: Pilot valve port**

Pilot valve port			ICS valve
SI	SII	P	
Open	Open	Closed	Open
Open	Open	Open	Open
Open	Closed	Closed	Closed
Open	Closed	Open	Open
Closed	Open	Closed	Closed
Closed	Open	Open	Open
Closed	Closed	Closed	Closed
Closed	Closed	Open	Open

**Figure 3: Blanking plug A + B** **Figure 4: Blanking plug A** **Figure 5: Example (ICS with 3 pilot valves)**

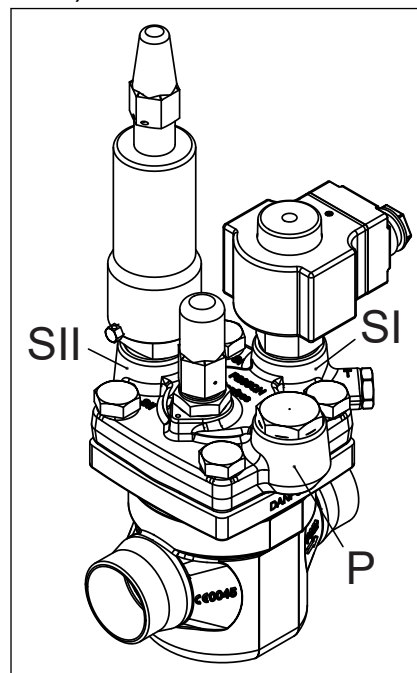
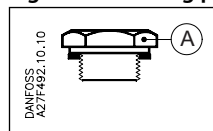
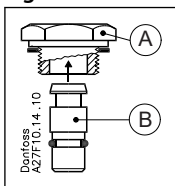

## Media

### **Refrigerants**

Applicable to HCFC, HFC, R717(Ammonia) and R744 (CO<sub>2</sub>).

Use with flammable hydrocarbons cannot be recommended; please contact Danfoss.

Surface protection ICS 25-150: The external surface is zinc-chromated to provide good corrosion protection.

### **New refrigerants**

Danfoss products are continually evaluated for use with new refrigerants depending on market requirements.

When a refrigerant is approved for use by Danfoss, it is added to the relevant portfolio, and the R number of the refrigerant (e.g. R513A) will be added to the technical data of the code number. Therefore, products for specific refrigerants are best checked at [store.danfoss.com/en/](https://store.danfoss.com/en/), or by contacting your local Danfoss representative.

## Product specification

### **Design**

ICS valves are designed as pilot operated valves requiring minimal pressure differential to open. If the pressure difference is 0 bar /0 psi, the ICS valve will be closed. If the pressure difference is 0.2 bar /3 psi or more, the ICS valve will be fully open. At pressure differences between 0.07 bar /1 psi and 0.2 bar /3 psi, the opening degree will be correspondingly proportional.

The ICS is available for use with either one or three pilot valves.

Two of the three pilot pressure connections (S1 and S2) are connected in series whilst the third (P) is connected in parallel to S1 and S2. This allows different combinations of pilot valves to be used, thus providing numerous variations in control functions.

Valve body and top cover material Low temperature steel

### **Pressure and temperature range**

#### **Temperature range**

-60 °C /+120 °C (-76 °F /+248 °F).

#### **Pressure range**

The valve is designed for: Max. working pressure: 52 bar (754 psig)

#### **Surface protection**

ICS 25-150: The external surface is zinc-chromated to provide good corrosion protection.

#### **Opening differential pressure:**

Fully open: Min. 0.2 bar (min. 3 psig); Max. Opening Pressure Differential (MOPD), solenoid valves only - at nominal conditions.

- 10 W a.c. up to 21 bar (305 psi)
- 20 W a.c. up to 40 bar (580 psi)

## The ICS Concept

The ICS concept is developed around a modular principle. This gives the possibility of combining function modules and top covers with special valve body size that is available in a variety of connection possibilities.

There are eight valve bodies available.

Figure 6: Valve bodies

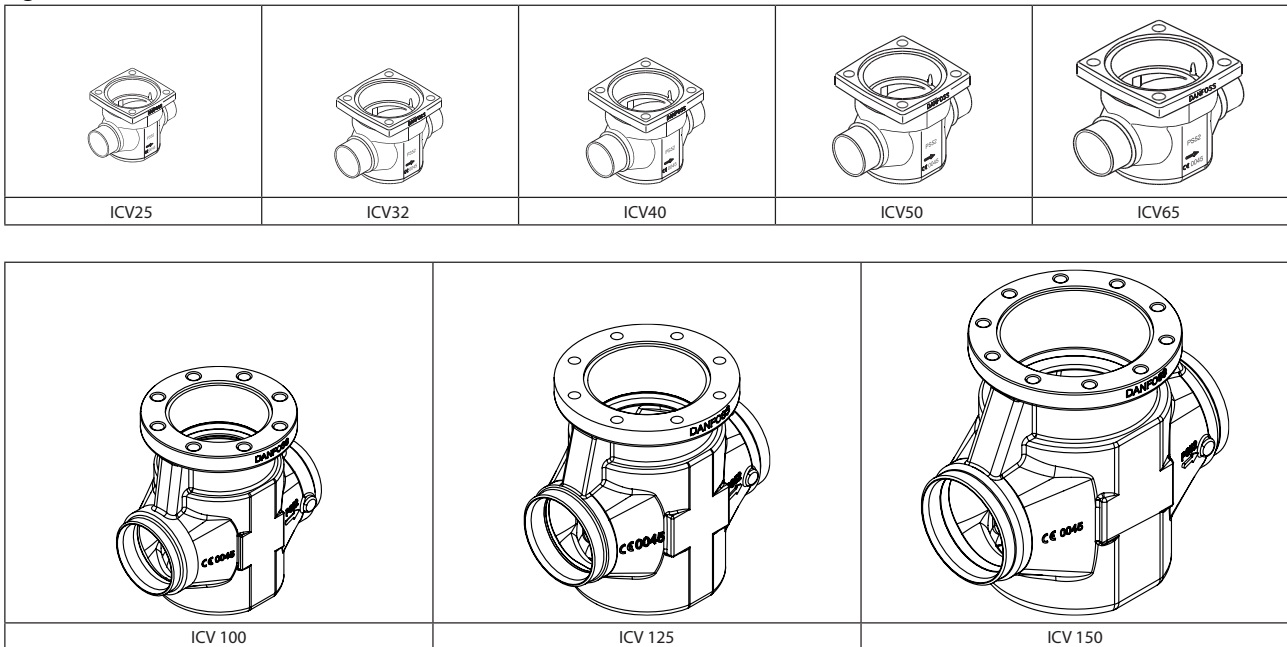

Valve bodies in the sizes ICV 20-ICV65 are available with a range of undersizes through oversized connection sizes and types.

ICV 100 - ICV 150 are available in butt-weld DIN and butt-weld ANSI nominal sizes

Figure 7: Valve body in sizes

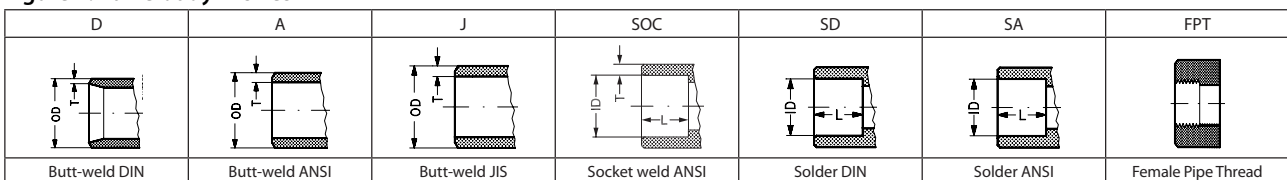

Each valve body may be fitted with a 1 pilot or 3 pilot top cover.

## Pilot-operated servo valve, type ICS

Figure 8: 1 pilot top cover

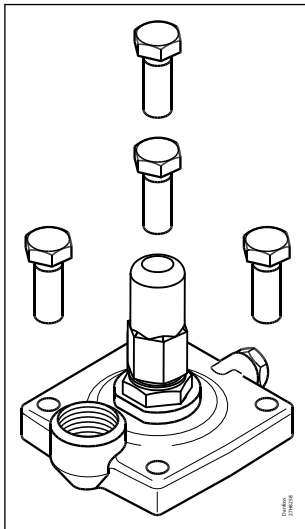
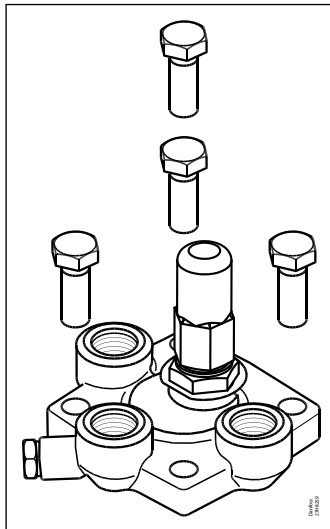
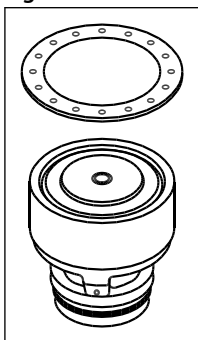

Figure 9: 3 pilot top cover



In ICS, multiple inserts (function modules) are available to give different capacities.

Figure 10: ICS function modules



Type	Valve body size	$K_v$ (m <sup>3</sup> /h)	$C_v$ (USgal/min)
ICS 25-5	25	1.7	2.0
ICS 25-10		3.5	4.1
ICS 25-15		6.0	7.0
ICS 25-20		8	9.3
ICS 25-25		11.5	13.3
ICS 32	32	17	20
ICS 40	40	27	31
ICS 50	50	44	51
ICS 65	65	70	81
ICS 80	80	85	98
ICS 100	100	142	165
ICS 125	125	207	240
ICS 150	150	354	410

## Connections

There is a very wide range of connection types available with ICS valves:

- D: Butt weld, DIN (2448)
- A: Butt weld, ANSI (B 36.10)
- J: Butt weld, JIS (B S 602)
- SOC: Socket weld, ANSI (B 16.11)
- SD: Solder connection, DIN (2856)
- SA: Solder connection, ANSI (B 16.22)
- FPT: Female pipe thread (ANSI/ASME B 1.20.1)

**Figure 11: D: Butt-weld  
DIN (2448)**

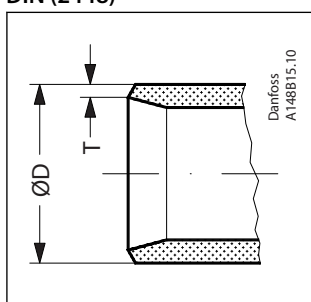

**Table 2: Butt-weld DIN**

Size mm	Size in.	OD mm	T mm	OD in.	T in.
20	(¾)	26.9	2.3	1.059	0.091
25	(1)	33.7	2.6	1.327	0.103
32	(1¼)	42.4	2.6	1.669	0.102
40	(1½)	48.3	2.6	1.902	0.103
50	(2)	60.3	2.9	2.37	0.11
65	(2½)	76.1	2.9	3	0.11
80	(3)	88.9	3.2	3.50	0.13
100	(4)	114.3	3.6	4.5	0.14
125	(5)	140.7	4	5.5	0.16
150	(6)	168.3	6.3	6.6	0.25

**Figure 12: A: Butt-weld  
ANSI (B 36.10)**

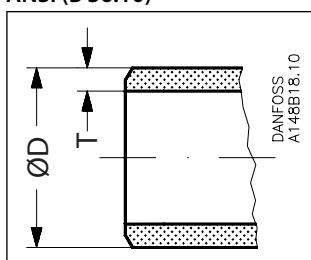

**Table 3: Butt-weld ANSI**

Size mm	Size in.	OD mm	T mm	OD in.	T in.	Schedule
(20)	¾	26.9	4.0	1.059	0.158	80
(25)	1	33.7	4.6	1.327	0.181	80
(32)	1¼	42.4	4.9	1.669	0.193	80
(40)	1½	48.3	5.1	1.902	0.201	80
(50)	2	60.3	3.9	2.37	0.15	40
(65)	2½	73.0	5.2	2.87	0.20	40
(80)	3	88.9	5.5	3.50	0.22	40

## Pilot-operated servo valve, type ICS

Size mm	Size in.	OD mm	T mm	OD in.	T in.	Schedule
(100)	4	114.3	6	4.5	0.24	
(125)	5	140.7	6.5	5.5	0.26	
(150)	6	168.3	7.1	6.6	0.28	

Figure 13: J: Butt-weld JIS

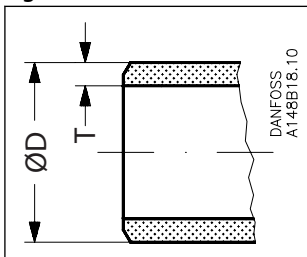

Table 4: Butt-weld JIS

Size mm	Size in.	OD mm	T mm	OD in.	T in.
(20)	¾	26.9	4.0	1.059	0.158
(25)	1	33.7	4.6	1.327	0.181
(32)	1¼	42.4	4.9	1.669	0.193
(40)	1½	48.3	5.1	1.902	0.201
(50)	2	60.3	3.9	2.37	0.15
(65)	2½	76.3	5.2	3.0	0.20

Figure 14: SOC: Socket welding ANSI (B 16.11)

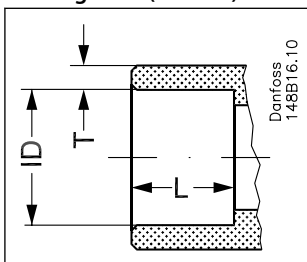
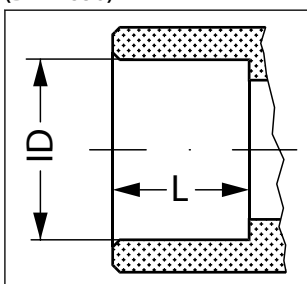

Table 5: Socket welding ANSI

Size mm	Size in.	OD mm	T mm	OD in.	T in.	L mm	L in.
(20)	¾	27.2	4.6	1.071	0.181	13	0.51
(25)	1	33.9	7.2	1.335	0.284	13	0.51
(32)	1¼	42.7	6.1	1.743	0.240	13	0.51
(40)	1½	48.8	6.6	1.921	0.260	13	0.51
(50)	2	61.2	6.2	2.41	0.24	16	0.63
(65)	2½	74	8.8	2.91	0.344	16	0.63

Figure 15: SD: Soldering (DIN 2856)



**Table 6: SD: Soldering DIN**

Size mm	ID mm	L mm
22	22.08	16.5
28	28.08	26
35	35.07	25
42	42.07	28
54	54.09	33
76	76.1	33

**Figure 16: SA: Soldering (ANSI B 16.22)**

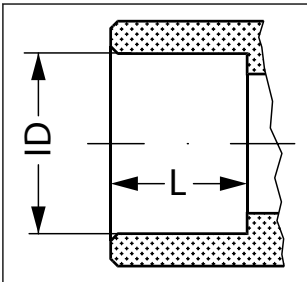

**Table 7: Socket welding ANSI**

Size in.	OD in.	L in.
3/8	0.875	0.650
1/2	1.125	1.024
3/4	1.375	1.024
1	1.625	1.102
1 1/2	2.125	1.300
2	2.625	1.300

**Figure 17: FPT: Female pipe thread, (ANSI/ASME B 1.20.1)**

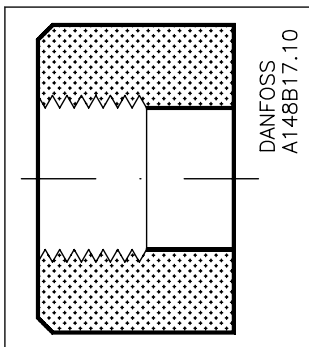

**Table 8: Socket welding ANSI**

Size mm	Size in.	Inside pipe thread
(20)	3/4	(3/4 × 14 NPT)
(25)	1	(1 × 11.5 NPT)
(32)	1 1/4	(1 1/4 × 11.5 NPT)

## Material specification

Figure 18: ICS 25, 32, 40, 50, 65

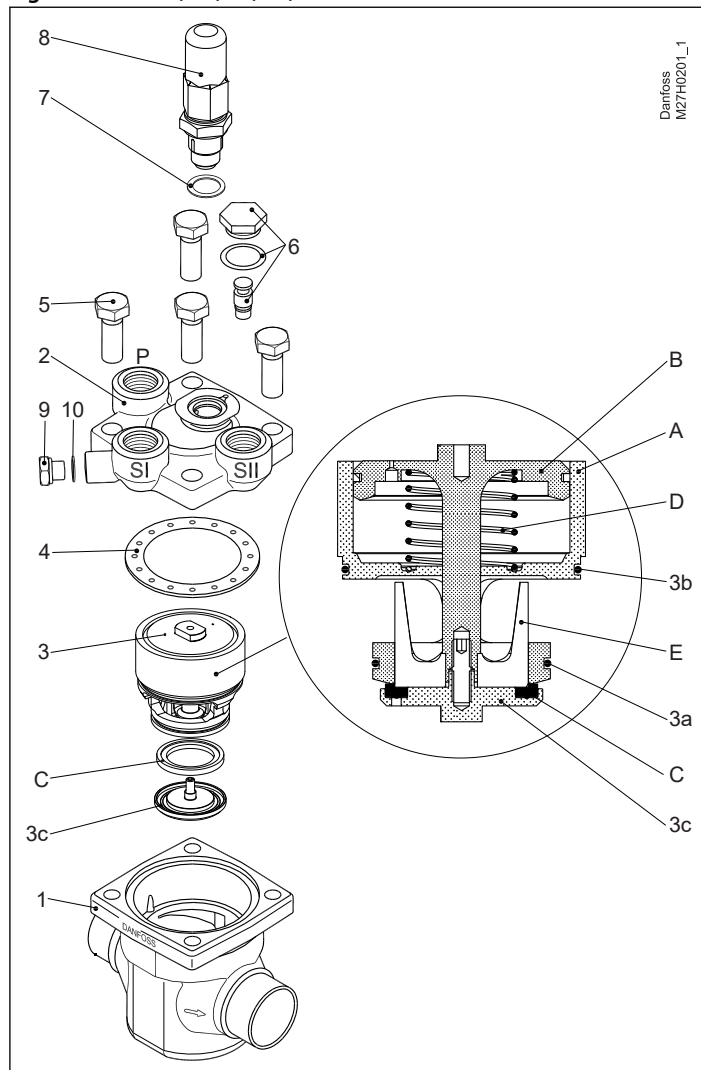

Table 9: Type and size of Bolt (pos. 5)

Type	Screw
ICS 25	M12 × 30 A2-70 DIN 933
ICS 32	M14 × 35 A2-70 DIN 933
ICS 40	M14 × 40 A2-70 DIN 933
ICS 50	M16 × 40 A2-70 DIN 933
ICS 65	M16 × 50 A2-70 DIN 933

Table 10: Material and parts list (ICS 25, 32, 40, 50, 65)

No.	Part	Material	EN	ASTM	JIS
1	Body	Low temperature steel	G20Mn5QT, EN 10213-3	LCC A352	SCPL1 G5151
2	Top cover	Low temperature steel	G20Mn5QT, EN 10213-3 P285QH+QT 10222-4	LCC A352 LF2, A350	SCPL1 G5151
3	Function module (assembled)				
3a	o-ring	Cloroprene (Neoprene)			
3b	o-ring	Cloroprene (Neoprene)			
3c	Washer plate	Steel			
A	Cylinder	Steel			
B	Piston	Steel			
C	Valve plate	PTFE			
D	Spring	Steel			

### Pilot-operated servo valve, type ICS

No.	Part	Material	EN	ASTM	JIS
E	Cone	Steel			
4	Gasket	Fiber, non-asbestos			
5	Bolts	Stainless steel	A2-70, EN 1515-1	Grade B8 A320	A2-70, B 1054
6	Plug	Steel			
7	Gasket	Aluminium			
8	Manual operating spindle	Steel			
9	Plug	Steel			
10	Gasket	Aluminium			

Figure 19: ICS 100, 125, 150

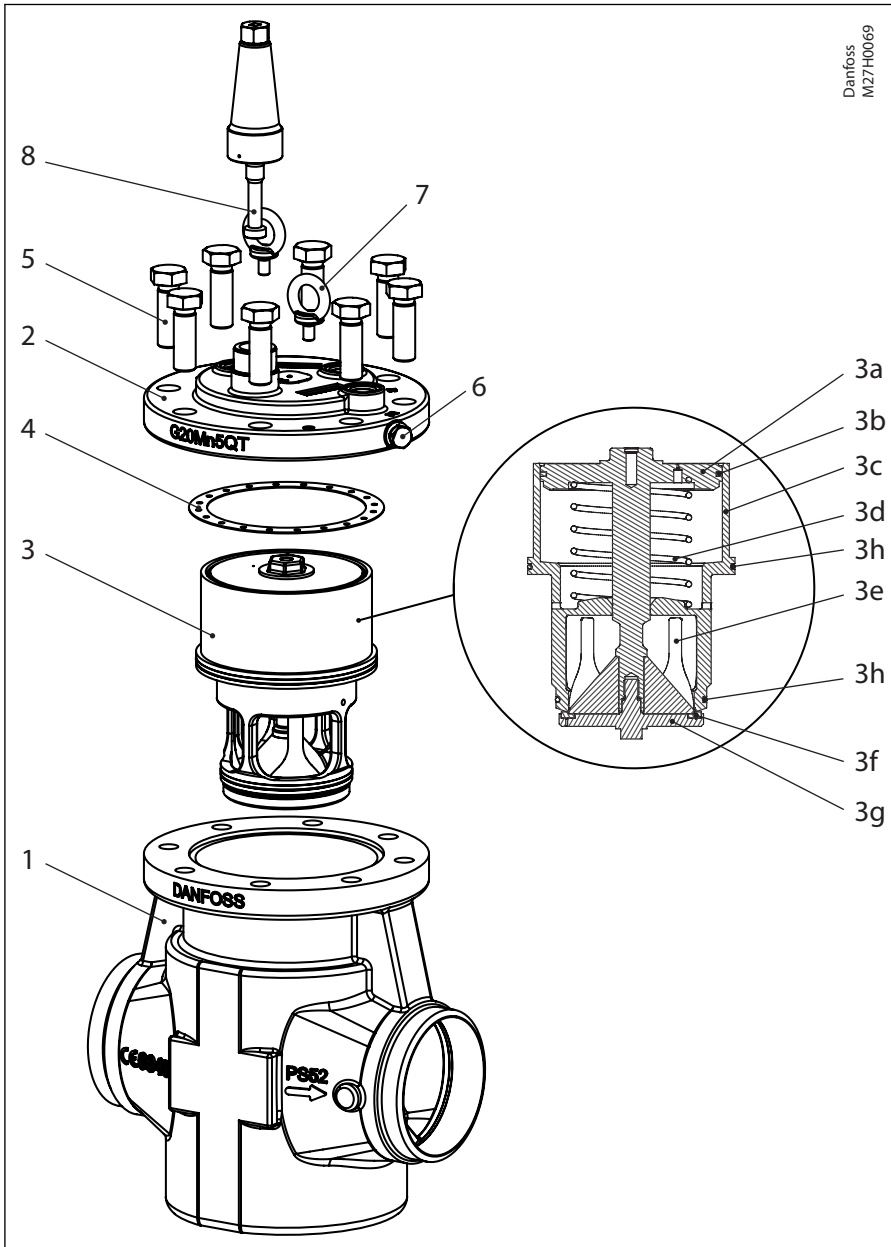

Table 11: Type and size of Bolt (pos. 5)

Type	Screw
ICS 100	M20 × 60 A2-70 DIN 933
ICS 125	M20 × 60 A2-70 DIN 933
ICS 150	M20 × 70 A2-70 DIN 933

## Pilot-operated servo valve, type ICS

**Table 12: Material and parts list (ICS 100, 125, 150)**

No.	Part	Material	EN	ASTM	JIS
1	Body	Low temperature steel	G20Mn5QT, EN 10213-3	LCC A352	SCPL1 G5151
2	Top cover	Low temperature steel	G20Mn5QT, EN 10213-3	LCC A352	SCPL1 G5151
3	Function module (assembled)				
3a	Piston/rod	Stainless steel / steel			
3b	Piston ring	Steel			
3c	Insert	Steel			
3d	Spring	Steel			
3e	Cone	Stainless steel / steel			
3f	Teflon plate	Teflon unfilled			
3g	Washer plate	PTFE			
3h	O-ring	Cloroprene (Neoprene)			
4	Gasket	Fiber, non-asbestos			
5	Bolts	Stainless steel	A2-70, EN 1515-1	Grade B8 A320	A2-70, B 1054
6	Plug	Steel			
7	Eye bolt	Galvanized steel			
8	Manual operating spindle	Steel			

## Configuration examples

**Table 13: Example no. 1**

<p><b>Example no. 1-1</b></p> <p>Constant pressure regulation</p> <ul style="list-style-type: none"> <li>• CVP-L (-0.66 to 7 bar g) (19.5 in. Hg to 102 psig)</li> <li>• CVP-M (4 to 28 bar g) (58 to 406 psig)</li> <li>• CVP-H (25 to 52 bar g) (363 to 754 psig)</li> </ul>	<p><b>Products</b></p> <p>1 × ICS 1 Pilot 1 × CVP-L/M/H</p>		<p><b>Products</b></p> <p>1 × ICS 3 Pilots 1 × CVP-L/M/H 2 × Blanking plugs SI: A + B SII: A</p>	
<p><b>Example no. 1-2</b></p> <p>Differential pressure regulation</p> <ul style="list-style-type: none"> <li>• CVPP-L (0.66 to 7 bar g) (19.5 in. Hg to 102 psig)</li> <li>• CVPP-M (4 to 28 bar g) (58 to 406 psig)</li> </ul>	<p><b>Products</b></p> <p>1 × ICS 1 Pilot 1 × CVPP-L/M</p>		<p><b>Products</b></p> <p>1 × ICS 3 Pilots 1 × CVPP-L/M 2 × Blanking plugs SI: A + B SII: A</p>	
<p><b>Example no. 1-3</b></p> <p>On/off regulation (solenoid valve)</p>	<p><b>Products</b></p> <p>1 × ICS 1 Pilot 1 × EVM 1 × coil</p>		<p><b>Products</b></p> <p>1 × ICS 3 Pilots 1 × EVM 1 × coil 2 × Blanking plugs SI: A + B SII: A</p>	
<p><b>Example no. 1-4</b></p> <p>Regulation with external control pressure</p>	<p><b>Products</b></p> <p>1 × ICS 1 Pilot 1 × nipple for external control pressure</p>		<p><b>Products</b></p> <p>1 × ICS 3 Pilots 1 × nipple for external control pressure 2 × Blanking plugs SI: A + B SII: A</p>	

## Pilot-operated servo valve, type ICS

<p><b>Example no. 1-5</b></p> <p>On/off regulation (sole-noid valve)</p>		<p><b>Products</b></p> <p>1 × ICS 1 Pilot 1 × EVM-NO (12 W coil)</p>		<p><b>Products</b></p> <p>1 × ICS 3 Pilots 1 × EVM-NO (12 W coil) 2 × Blanking plugs SI: A + B SII: A</p>	
<p><b>Example no. 1-6</b></p> <p>Crankcase pressure regulation. (Max. suction pressure regulation)</p> <ul style="list-style-type: none"> <li>-0.45 to 7 bar g (13.3 in. Hg to 102 psig)</li> </ul>		<p><b>Products</b></p> <p>1 × ICS 1 Pilot 1 × CVC-L</p>		<p><b>Products</b></p> <p>1 × ICS 3 Pilots 1 × CVC-L 2 × Blanking plugs SI: A + B SII: A</p>	
<p><b>Example no. 1-7</b></p> <p>Electronically controlled media temperature regulation</p> <ul style="list-style-type: none"> <li>-0.66 to 8 bar g (19.5 in. Hg to 116 psig)</li> </ul>		<p><b>Products</b></p> <p>1 × ICS 1 Pilot 1 × CVE</p>		<p><b>Products</b></p> <p>1 × ICS 3 Pilots 1 × CVE 2 × Blanking plugs SI: A + B SII: A</p>	

**Table 14: Example no. 2**

<p><b>Example no. 2-1</b></p> <p>Constant pressure regulation combined with electrical shut off</p> <ul style="list-style-type: none"> <li>-0.66 bar to 7 bar (19.5 in. Hg to 102 psig)</li> </ul>		<p><b>Products</b></p> <p>1 × ICS 3 Pilots 1 × blanking plug (A + B) 1 × CVP-L 1 × EVM 1 × coil</p>	
<p><b>Example no. 2-2</b></p> <p>Constant pressure regulation combined with electrical wide open</p>		<p><b>Products</b></p> <p>1 × ICS 3 Pilots 1 × blanking plug (A) 1 × CVP-L 1 × EVM</p>	
<p><b>Example no. 2-3</b></p> <p>Constant pressure regulation combined with electrical shut off and wide open</p> <ul style="list-style-type: none"> <li>-0.66 bar to 7 bar (19.5 in. Hg to 102 psig)</li> </ul>		<p><b>Products</b></p> <p>1 × ICS 3 Pilots 1 × CVP-L 2 × EVM 2 × coils</p>	

## Pilot-operated servo valve, type ICS

<p><b>Example no. 2-4</b></p> <p>Constant pressure regulation with change-over between two preset evaporating pressures</p> <ul style="list-style-type: none"> <li>-0.66 bar to 7 bar (19.5 in. Hg to 102 psig)</li> </ul>		<p><b>Products</b></p> <ul style="list-style-type: none"> <li>1 × ICS 3 Pilots</li> <li>2 × CVP-L</li> <li>1 × EVM</li> <li>1 × coil</li> </ul>	
<p><b>Example no. 2-5</b></p> <p>External control pressure with electrical shut off combined with constant pressure regulation</p> <ul style="list-style-type: none"> <li>-0.66 bar to 7 bar (19.5 in. Hg to 102 psig)</li> </ul>		<p><b>Products</b></p> <ul style="list-style-type: none"> <li>1 × ICS 3 Pilots</li> <li>1 × Nipple for external control pressure</li> <li>1 × CVP-L</li> <li>1 × EVM</li> <li>1 × Coil</li> </ul>	
<p><b>Example no. 2-6</b></p> <p>Constant pressure regulation with external control pressure combined with electrical wide open</p> <ul style="list-style-type: none"> <li>-0.66 bar to 7 bar (19.5 in. Hg to 102 psig)</li> </ul>		<p><b>Products</b></p> <ul style="list-style-type: none"> <li>1 × ICS 3 Pilots</li> <li>1 × Nipple for external control pressure</li> <li>1 × CVP-L</li> <li>1 × EVM</li> <li>1 × Coil</li> </ul>	
<p><b>Example no. 2-7</b></p> <p>Constant pressure regulation with electrical shut off combined with external control pressure</p> <ul style="list-style-type: none"> <li>-0.66 bar to 7 bar (19.5 in. Hg to 102 psig)</li> </ul>		<p><b>Products</b></p> <ul style="list-style-type: none"> <li>1 × ICS 3 Pilots</li> <li>1 × Nipple for external control pressure</li> <li>1 × CVP-L</li> <li>1 × EVM</li> <li>1 × Coil</li> </ul>	
<p><b>Example no. 2-8</b></p> <p>Solenoid valve with external control pressure for small pressure drops</p>		<p><b>Products</b></p> <ul style="list-style-type: none"> <li>1 × ICS 3</li> <li>1 × Blanking plug (A + B)</li> <li>1 × Nipple for external control pressure</li> <li>1 × EVM</li> <li>1 × Coil</li> </ul>	
<p><b>Example no. 2-9</b></p> <p>Differential pressure regulation combined with electrical shut off</p> <ul style="list-style-type: none"> <li>CVPP-L (0.66 bar to 7 bar) (19.5 in. Hg to 102 psig)</li> </ul>		<p><b>Products</b></p> <ul style="list-style-type: none"> <li>1 × ICS 3</li> <li>1 × Blanking plug (A + B)</li> <li>1 × CVPP-L</li> <li>1 × EVM</li> <li>1 × Coil</li> </ul>	

## Pilot-operated servo valve, type ICS

### Example no. 2-10

Differential pressure regulation combined with electrical wide open

- CVPP-L (0.66 bar to 7 bar) (19.5 in. Hg to 102 psig)

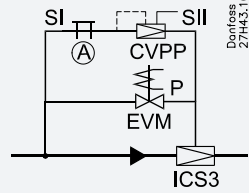

Danfoss  
27H43.10

### Products

- 1 × ICS 3 Pilots
- 1 × Blanking plug (A)
- 1 × CVPP-L
- 1 × EVM
- 1 × Coil

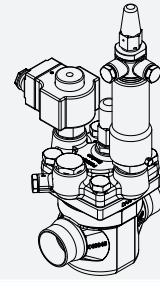

### Example no. 2-11

Differential pressure regulation combined with electrical wide open and shut off

- CVPP-L (0.66 bar to 7 bar) (19.5 in. Hg to 102 psig)

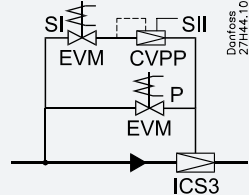

Danfoss  
27H44.10

### Products

- 1 × ICS 3 Pilots
- 1 × CVPP-L
- 2 × EVM
- 2 × Coils

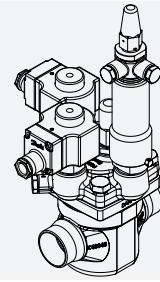

### Example no. 2-12

Constant pressure regulation combined with electrical shut off

- CVP-L (-0.66 bar to 7 bar) (19.5 in. Hg to 102 psig)
- CVP-M (4 bar to 28 bar) (58 to 406 psig)
- CVP-H (25 bar to 52 bar) (363 to 754 psig)

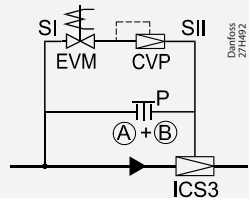

Danfoss  
27H49.2

### Products

- 1 × ICS 3 Pilots
- 1 × Blanking plug (A + B)
- 1 × CVP-L/M/H
- 1 × EVM
- 1 × Coil

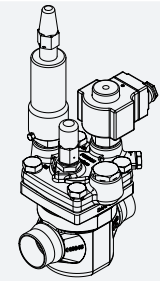

### Example no. 2-13

Constant pressure regulation combined with electrical wide open

- CVP-L (-0.66 bar to 7 bar) (19.5 in. Hg to 102 psig)
- CVP-M (4 bar to 28 bar) (58 to 406 psig)
- CVP-H (25 bar to 52 bar) (363 to 754 psig)

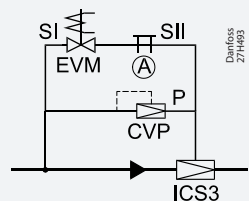

Danfoss  
27H49.3

### Products

- 1 × ICS 3 Pilots
- 1 × Blanking plug (A)
- 1 × CVP-L/M/H
- 1 × EVM
- 1 × Coil

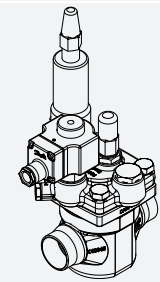

### Example no. 2-14

Constant pressure regulation combined with electrical shut off and wide open

- CVP-L (-0.66 bar to 7 bar) (19.5 in. Hg to 102 psig)
- CVP-M (4 bar to 28 bar) (58 to 406 psig)
- CVP-H (25 bar to 52 bar) (363 to 754 psig)

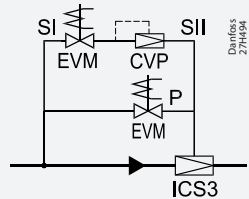

Danfoss  
27H49.4

### Products

- 1 × ICS 3 Pilots
- 1 × CVP-L/M/H
- 2 × EVM
- 2 × Coils

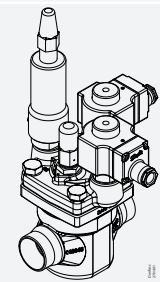

### Example no. 2-15

Constant pressure regulation with change-over between two preset evaporating pressures

- CVP-L (-0.66 bar to 7 bar) (19.5 in. Hg to 102 psig)
- CVP-M (4 bar to 28 bar) (58 to 406 psig)
- CVP-H (25 bar to 52 bar) (363 to 754 psig)

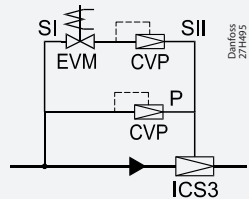

Danfoss  
27H49.5

### Products

- 1 × ICS 3 Pilots
- 2 × CVP-L/M/H
- 1 × EVM
- 1 × Coil

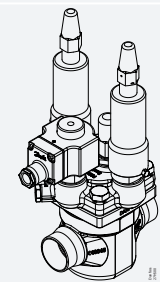

## Pilot-operated servo valve, type ICS

<p><b>Example no. 2-16</b></p> <p>Differential pressure regulation combined with electrical shut off</p> <ul style="list-style-type: none"> <li>• CVPP-L (-0.66 bar to 7 bar) (19.5 in. Hg to 102 psig)</li> <li>• CVPP-M (4 bar to 28 bar) (58 to 406 psig)</li> </ul>		<p><b>Products</b></p> <ul style="list-style-type: none"> <li>1 × ICS 3 Pilots</li> <li>1 × Blanking plug (A + B)</li> <li>1 × CVPP-L/M</li> <li>1 × EVM</li> <li>1 × Coil</li> </ul>	
<p><b>Example no. 2-17</b></p> <p>Differential pressure regulation combined with electrical wide open</p> <ul style="list-style-type: none"> <li>• CVPP-L (-0.66 bar to 7 bar) (19.5 in. Hg to 102 psig)</li> <li>• CVPP-M (4 bar to 28 bar) (58 to 406 psig)</li> </ul>		<p><b>Products</b></p> <ul style="list-style-type: none"> <li>1 × ICS 3 Pilots</li> <li>1 × Blanking plug (A)</li> <li>1 × CVPP-L/M</li> <li>1 × EVM</li> <li>1 × Coil</li> </ul>	
<p><b>Example no. 2-18</b></p> <p>Differential pressure regulation combined with electrical wide open and shut off</p> <ul style="list-style-type: none"> <li>• CVPP-L (-0.66 bar to 7 bar) (19.5 in. Hg to 102 psig)</li> <li>• CVPP-M (4 bar to 28 bar) (58 to 406 psig)</li> </ul>		<p><b>Products</b></p> <ul style="list-style-type: none"> <li>1 × ICS 3 Pilots</li> <li>1 × CVPP-L/M</li> <li>2 × EVM</li> <li>2 × Coils</li> </ul>	
<p><b>Example no. 2-19</b></p> <p>Constant pressure regulation combined with electrical wide open and shut off</p> <ul style="list-style-type: none"> <li>• CVP-L (-0.66 bar to 7 bar) (19.5 in. Hg to 102 psig)</li> <li>• CVP-M (4 bar to 28 bar) (58 to 406 psig)</li> <li>• CVP-H (25 bar to 52 bar) (363 to 754 psig)</li> </ul>		<p><b>Products</b></p> <ul style="list-style-type: none"> <li>1 × ICS 3 Pilots</li> <li>1 × CVP-L/M/H</li> <li>1 × EVM</li> <li>1 × EVM-NO (12 W coil)</li> <li>2 × Coils</li> </ul>	
<p><b>Example no. 2-20</b></p> <p>Crankcase pressure regulation (max. suction pressure regulation) combined with shut off</p> <ul style="list-style-type: none"> <li>• -0.45 bar to 7 bar (13.3 in. Hg to 102 psig)</li> </ul>		<p><b>Products</b></p> <ul style="list-style-type: none"> <li>1 × ICS 3 Pilots</li> <li>1 × Blanking plug (A + B)</li> <li>1 × CVC-L</li> <li>1 × EVM</li> <li>1 × Coil</li> </ul>	
<p><b>Example no. 2-21</b></p> <p>Crankcase pressure regulation (max. suction pressure regulation) combined with evaporating pressure regulation</p> <ul style="list-style-type: none"> <li>• -0.66 bar to 28 bar (19.5 in. Hg to 406 psig).</li> </ul>		<p><b>Products</b></p> <ul style="list-style-type: none"> <li>1 × ICS 3 Pilots</li> <li>1 × Blanking plug (A + B)</li> <li>1 × CVC-L/M</li> <li>1 × CVP-L/M</li> </ul>	

## Pilot-operated servo valve, type ICS

<p><b>Example no. 2-22</b></p> <p>Crankcase pressure regulation (max. suction pressure regulation) at low pressure drops across the valve</p> <ul style="list-style-type: none"> <li>-0.45 bar to 7 bar (13.3 in. Hg to 102 psig)</li> </ul>		<p><b>Products</b></p> <ul style="list-style-type: none"> <li>1 × ICS 3 Pilots</li> <li>1 × Blanking plug (A + B)</li> <li>1 × Nipple for external control pressure</li> <li>1 × CVC-L</li> </ul>	
<p><b>Example no. 2-23</b></p> <p>Crankcase pressure regulation (max. suction pressure regulation) combined with constant pressure regulation and electrical shut off.</p> <ul style="list-style-type: none"> <li>-0.66 bar to 7 bar (19.5 in. Hg to 102 psig).</li> </ul>		<p><b>Products</b></p> <ul style="list-style-type: none"> <li>1 × ICS 3 Pilots</li> <li>1 × Blanking plug (A + B)</li> <li>1 × Nipple for external control pressure</li> <li>1 × CVP-L</li> <li>1 × EVM</li> <li>1 × Coil</li> <li>2 × CVH</li> <li>1 × CVC-L</li> </ul>	
<p><b>Example no. 2-24</b></p> <p>Hot gas bypass regulation combined with electrical shut off</p> <ul style="list-style-type: none"> <li>-0.45 bar to 7 bar (13.3 in. Hg to 102 psig)</li> </ul>		<p><b>Products</b></p> <ul style="list-style-type: none"> <li>1 × ICS 3 Pilots</li> <li>1 × Blanking plug (A + B)</li> <li>1 × CVC-L</li> <li>1 × EVM</li> <li>1 × Coil</li> </ul>	
<p><b>Example no. 2-25</b></p> <p>Constant pressure regulation with electrical shut off and protection against high pressure when suction line is closed</p> <ul style="list-style-type: none"> <li>-0.66 bar to 28 bar (19.5 in. Hg to 406 psig).</li> </ul>		<p><b>Products</b></p> <ul style="list-style-type: none"> <li>1 × ICS 3 Pilots</li> <li>1 × CVP-L</li> <li>1 × EVM</li> <li>1 × Coil</li> <li>1 × CVP-M</li> </ul>	
<p><b>Example no. 2-26</b></p> <p>Electronically controlled media temperature regulation combined with electrical shut off</p> <ul style="list-style-type: none"> <li>-1 bar to 8 bar (0 in. Hg to 116 psig).</li> </ul>		<p><b>Products</b></p> <ul style="list-style-type: none"> <li>1 × ICS 3 Pilots</li> <li>1 × Blanking plug (A + B)</li> <li>1 × CVE</li> <li>1 × EVM</li> <li>1 × Coil</li> </ul>	
<p><b>Example no. 2-27</b></p> <p>Electronically controlled media temperature regulation combined with electrical shut off and wide open</p> <ul style="list-style-type: none"> <li>-1 bar to 8 bar (0 in. Hg to 116 psig).</li> </ul>		<p><b>Products</b></p> <ul style="list-style-type: none"> <li>1 × ICS 3 Pilots</li> <li>1 × CVE</li> <li>2 × EVM</li> <li>2 × Coils</li> </ul>	

## Pilot-operated servo valve, type ICS

### Example no. 2-28

Electronically controlled media temperature regulation combined with electrical shut off and changeover to constant pressure regulation

- 1 bar to 8 bar (0 in. Hg to 116 psig).

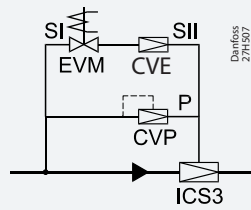

Danfoss  
27H507

### Products

- 1 × ICS 3 Pilots
- 1 × CVQ
- 1 × CVP-L
- 1 × EVM
- 1 × Coil

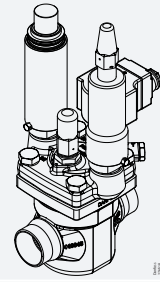

### Example no. 2-29

Electronically controlled media temperature regulation with low evaporating pressure protection combined with wide open

- 1 bar to 8 bar (0 in. Hg to 116 psig).

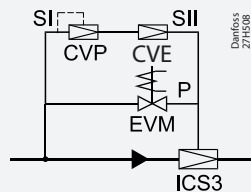

Danfoss  
27H508

### Products

- 1 × ICS 3 Pilots
- 1 × CVE
- 1 × CVP-L
- 1 × EVM
- 1 × Coil

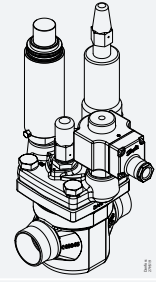

### Example no. 2-30

Electronically controlled media temperature regulation with low evaporating pressure protection combined with changeover to constant pressure regulation

- 1 bar to 8 bar (0 in. Hg to 116 psig).

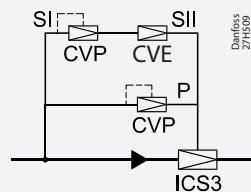

Danfoss  
27H509

### Products

- 1 × ICS 3 Pilots
- 1 × CVE
- 2 × CVP-L

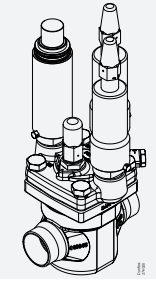

## Valve selection based on capacity calculation

As for extended capacity calculations and valve selection based on capacities and refrigerants, please refer to Coolselector®2. Rated and extended capacities are calculated with the Coolselector®2 calculation engine to ARI standards with the ASEREP equations based on laboratory measurements of selected valves.

Download Coolselector®2 for free at [coolselector.danfoss.com](http://coolselector.danfoss.com).

## Dimensions and weights

### ICS 25-5 to ICS 25-25

Figure 20: Dimensions and weights - ICS 25-5 to ICS 25-25

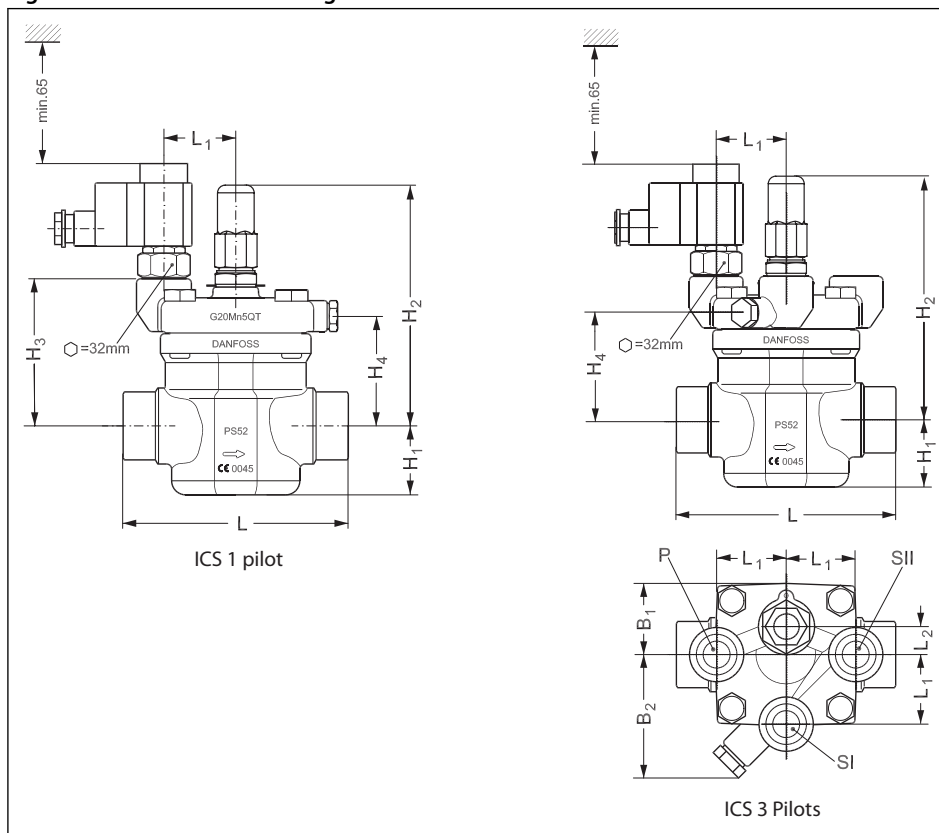

Table 15: Connection type and Weight

Connection		H <sub>1</sub>	H <sub>2</sub>	H <sub>3</sub>	H <sub>4</sub>	L	L <sub>1</sub>	L <sub>2</sub>	B <sub>1</sub>	B <sub>2</sub>	Weight ICS 1 Pilot	Weight ICS 3 Pilots
20 D (¾ in.)	mm in.	37 1.46	145 5.71	86 3.39	60 2.36	135 5.31	42 1.65	15 0.59	42 1.65	87 3.43	3 kg 6.6 lb.	3.6 kg 7.92 lb.
25 D (1 in.)	mm in.	37 1.46	145 5.71	86 3.39	60 2.36	135 5.31	42 1.65	15 0.59	42 1.65	87 3.43	3 kg 6.6 lb.	3.6 kg 7.92 lb.
32 D (1¼ in.)	mm in.	37 1.46	145 5.71	86 3.39	60 2.36	135 5.31	42 1.65	15 0.59	42 1.65	87 3.43	3 kg 6.6 lb.	3.6 kg 7.92 lb.
40 D (1½ in.)	mm in.	37 1.46	145 5.71	86 3.39	60 2.36	135 5.31	42 1.65	15 0.59	42 1.65	87 3.43	3 kg 6.6 lb.	3.6 kg 7.92 lb.
20 A (¾ in.)	mm in.	37 1.46	145 5.71	86 3.39	60 2.36	135 5.31	42 1.65	15 0.59	42 1.65	87 3.43	3 kg 6.6 lb.	3.6 kg 7.92 lb.
25 A (1 in.)	mm in.	37 1.46	145 5.71	86 3.39	60 2.36	135 5.31	42 1.65	15 0.59	42 1.65	87 3.43	3 kg 6.6 lb.	3.6 kg 7.92 lb.
32 A (1¼ in.)	mm in.	37 1.46	145 5.71	86 3.39	60 2.36	135 5.31	42 1.65	15 0.59	42 1.65	87 3.43	3 kg 6.6 lb.	3.6 kg 7.92 lb.
20 SOC (¾ in.)	mm in.	37 1.46	145 5.71	86 3.39	60 2.36	135 5.31	42 1.65	15 0.59	42 1.65	87 3.43	3 kg 6.6 lb.	3.6 kg 7.92 lb.
25 SOC (1 in.)	mm in.	37 1.46	145 5.71	86 3.39	60 2.36	147 5.79	42 1.65	15 0.59	42 1.65	87 3.43	3 kg 6.6 lb.	3.6 kg 7.92 lb.
22 SD (¾ in.)	mm in.	37 1.46	145 5.71	86 3.39	60 2.36	135 5.31	42 1.65	15 0.59	42 1.65	87 3.43	3 kg 6.6 lb.	3.6 kg 7.92 lb.
28 SD (1½ in.)	mm in.	37 1.46	145 5.71	86 3.39	60 2.36	147 5.78	42 1.65	15 0.59	42 1.65	87 3.43	3 kg 6.6 lb.	3.6 kg 7.92 lb.
22 SA (¾ in.)	mm in.	37 1.46	145 5.71	86 3.39	60 2.36	135 5.31	42 1.65	15 0.59	42 1.65	87 3.43	3 kg 6.6 lb.	3.6 kg 7.92 lb.
28 SA (1½ in.)	mm in.	37 1.46	145 5.71	86 3.39	60 2.36	147 5.78	42 1.65	15 0.59	42 1.65	87 3.43	3 kg 6.6 lb.	3.6 kg 7.92 lb.

## Pilot-operated servo valve, type ICS

Connection		H <sub>1</sub>	H <sub>2</sub>	H <sub>3</sub>	H <sub>4</sub>	L	L <sub>1</sub>	L <sub>2</sub>	B <sub>1</sub>	B <sub>2</sub>	Weight ICS 1 Pilot	Weight ICS 3 Pilots
35 SA (1 3/8 in.)	mm	37	145	86	60	147	42	15	42	87	3 kg	3.6 kg
	in.	1.46	5.71	3.39	2.36	5.78	1.65	0.59	1.65	3.43	6.6 lb.	7.92 lb.
20 FPT (3/4 in.)	mm	37	145	86	60	135	42	15	42	87	3 kg	3.6 kg
	in.	1.46	5.71	3.39	2.36	5.31	1.65	0.59	1.65	3.43	6.6 lb.	7.92 lb.
25 FPT (1 in.)	mm	37	145	86	60	135	42	15	42	87	3 kg	3.6 kg
	in.	1.46	5.71	3.39	2.36	5.31	1.65	0.59	1.65	3.43	6.6 lb.	7.92 lb.

**NOTE:**

Specified weights are approximate values only.

**D** = Butt-weld DIN

**A** = Butt-weld ANSI

**J** = Butt-weld JIS

**SOC** = Socket weld ANSI

**SD** = Solder DIN

**SA** = Solder ANSI

**FPT** = Female Pipe Thread

### ICS 32

Figure 21: ICS 32, Dimensions and weights

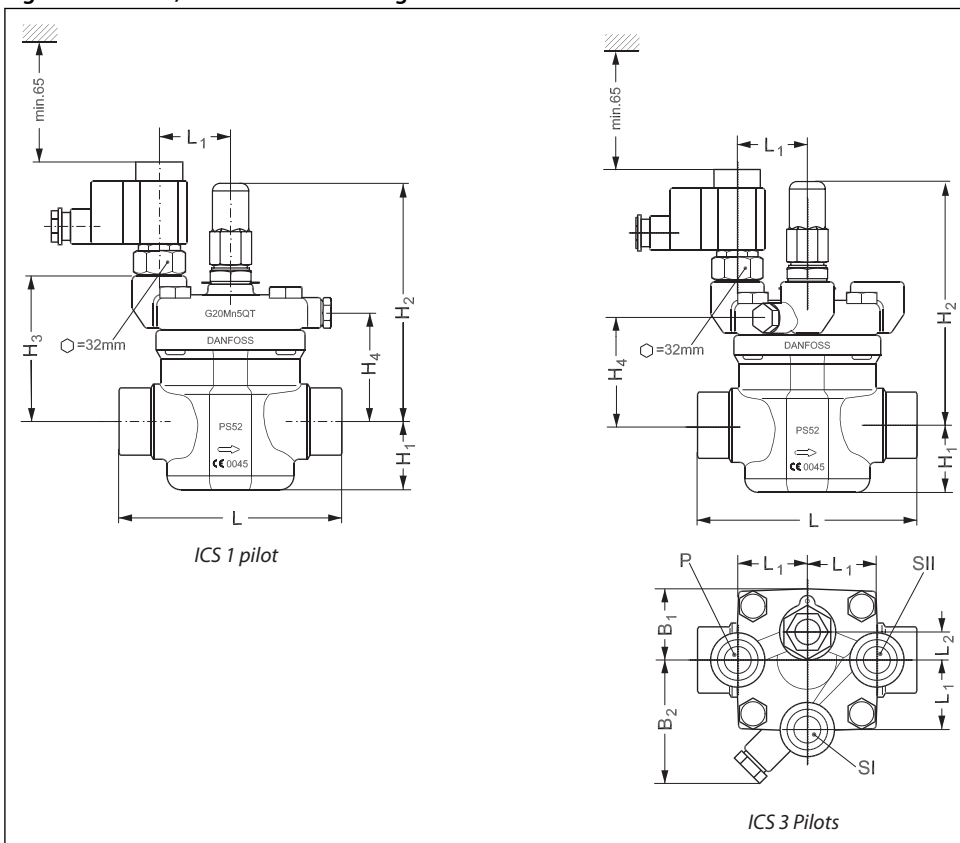

Table 16: Connection type and Weight

Connection		H <sub>1</sub>	H <sub>2</sub>	H <sub>3</sub>	H <sub>4</sub>	L	L <sub>1</sub>	L <sub>2</sub>	B <sub>1</sub>	B <sub>2</sub>	Weight ICS 1 Pilot	Weight ICS 3 Pilots
32 D (1 1/4 in.)	mm	40	160	100	74	145	51	15	51	87	4.5 kg	5 kg
	in.	1.57	6.30	3.93	2.91	5.71	2.00	0.59	2.00	3.43	9.9 lb.	11 lb.
40 D (1 1/2 in.)	mm	40	160	100	74	145	51	15	51	87	4.5 kg	5 kg
	in.	1.57	6.30	3.93	2.91	5.71	2.00	0.59	2.00	3.43	9.9 lb.	11 lb.
32 A (1 1/4 in.)	mm	40	160	100	74	145	51	15	51	87	4.5 kg	5 kg
	in.	1.57	6.30	3.93	2.91	5.71	2.00	0.59	2.00	3.43	9.9 lb.	11 lb.

## Pilot-operated servo valve, type ICS

Connection		H <sub>1</sub>	H <sub>2</sub>	H <sub>3</sub>	H <sub>4</sub>	L	L <sub>1</sub>	L <sub>2</sub>	B <sub>1</sub>	B <sub>2</sub>	Weight ICS 1 Pilot	Weight ICS 3 Pilots
40 A (1½ in.)	mm in.	40 1.57	160 6.30	100 3.93	74 2.91	145 5.71	51 2.00	15 0.59	51 2.00	87 3.43	4.5 kg 9.9 lb.	5 kg 11 lb.
32 SOC (1¼ in.)	mm in.	40 1.57	160 6.30	100 3.93	74 2.91	145 5.71	51 2.00	15 0.59	51 2.00	87 3.43	4.5 kg 9.9 lb.	5 kg 11 lb.
35 SD (1⅜ in. SA)	mm in.	40 1.57	160 6.30	100 3.93	74 2.91	145 5.71	51 2.00	15 0.59	51 2.00	87 3.43	4.5 kg 9.9 lb.	5 kg 11 lb.
42 SD (1⅝ in.)	mm in.	40 1.57	160 6.30	100 3.93	74 2.91	145 5.71	51 2.00	15 0.59	51 2.00	87 3.43	4.5 kg 9.9 lb.	5 kg 11 lb.
42 SA (1⅝ in.)	mm in.	40 1.57	160 6.30	100 3.93	74 2.91	145 5.71	51 2.00	15 0.59	51 2.00	87 3.43	4.5 kg 9.9 lb.	5 kg 11 lb.

**NOTE:**

Specified weights are approximate values only.

**D** = Butt-weld DIN

**A** = Butt-weld ANSI

**J** = Butt-weld JIS

**SOC** = Socket weld ANSI

**SD** = Solder DIN

**SA** = Solder ANSI

**FPT** = Female Pipe Thread

### ICS 40

Figure 22: ICS 40, Dimensions and weights

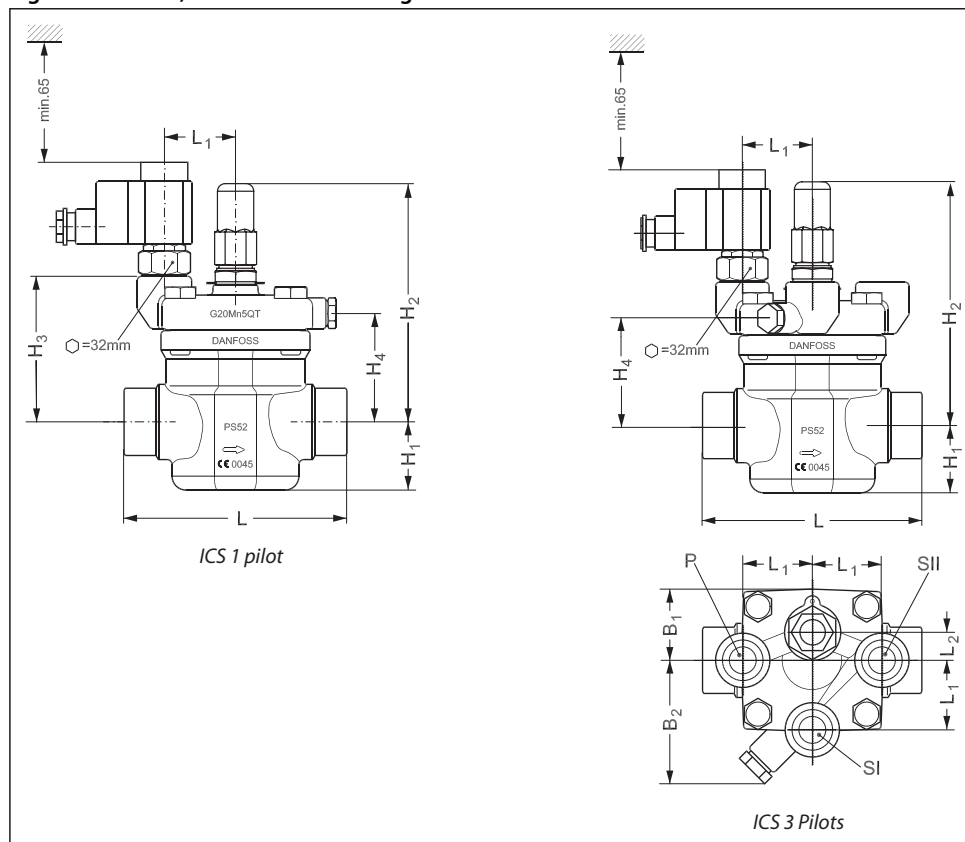

Pilot-operated servo valve, type ICS

Table 17: Connection type and Weight

Connection		H <sub>1</sub>	H <sub>2</sub>	H <sub>3</sub>	H <sub>4</sub>	L	L <sub>1</sub>	L <sub>2</sub>	B <sub>1</sub>	B <sub>2</sub>	Weight ICS 1 Pilot	Weight ICS 3 Pilots
40 D (1½ in.)	mm in.	49 1.93	166 6.54	105 4.13	78 3.07	160 6.30	51 2.00	15 0.59	54 2.13	87 3.43	5.9 kg 13.0 lb.	6.3 kg 13.9 lb.
50 D (2 in.)	mm in.	49 1.93	166 6.54	105 4.13	78 3.07	180 7.09	51 2.00	15 0.59	54 2.13	87 3.43	5.9 kg 13.0 lb.	6.3 kg 13.9 lb.
40 A (1½ in.)	mm in.	49 1.93	166 6.54	105 4.13	78 3.07	160 6.30	51 2.00	15 0.59	54 2.13	87 3.43	5.9 kg 13.0 lb.	6.3 kg 13.9 lb.
50 A (2 in.)	mm in.	49 1.93	166 6.54	105 4.13	78 3.07	180 7.09	51 2.00	15 0.59	54 2.13	87 3.43	5.9 kg 13.0 lb.	6.3 kg 13.9 lb.
40 SOC (1½ in.)	mm in.	49 1.93	166 6.54	105 4.13	78 3.07	180 7.09	51 2.00	15 0.59	54 2.13	87 3.43	5.9 kg 13.0 lb.	6.3 kg 13.9 lb.
42 SD (1½ in.)	mm in.	49 1.93	166 6.54	105 4.13	78 3.07	180 7.09	51 2.00	15 0.59	54 2.13	87 3.43	5.9 kg 13.0 lb.	6.3 kg 13.9 lb.
42 SA (1½ in.)	mm in.	49 1.93	166 6.54	105 4.13	78 3.07	180 7.09	51 2.00	15 0.59	54 2.13	87 3.43	5.9 kg 13.0 lb.	6.3 kg 13.9 lb.

**NOTE:**

Specified weights are approximate values only.

**D** = Butt-weld DIN

**A** = Butt-weld ANSI

**J** = Butt-weld JIS

**SOC** = Socket weld ANSI

**SD** = Solder DIN

**SA** = Solder ANSI

**FPT** = Female Pipe Thread

**ICS 50**

Figure 23: ICS 50, Dimensions and weights

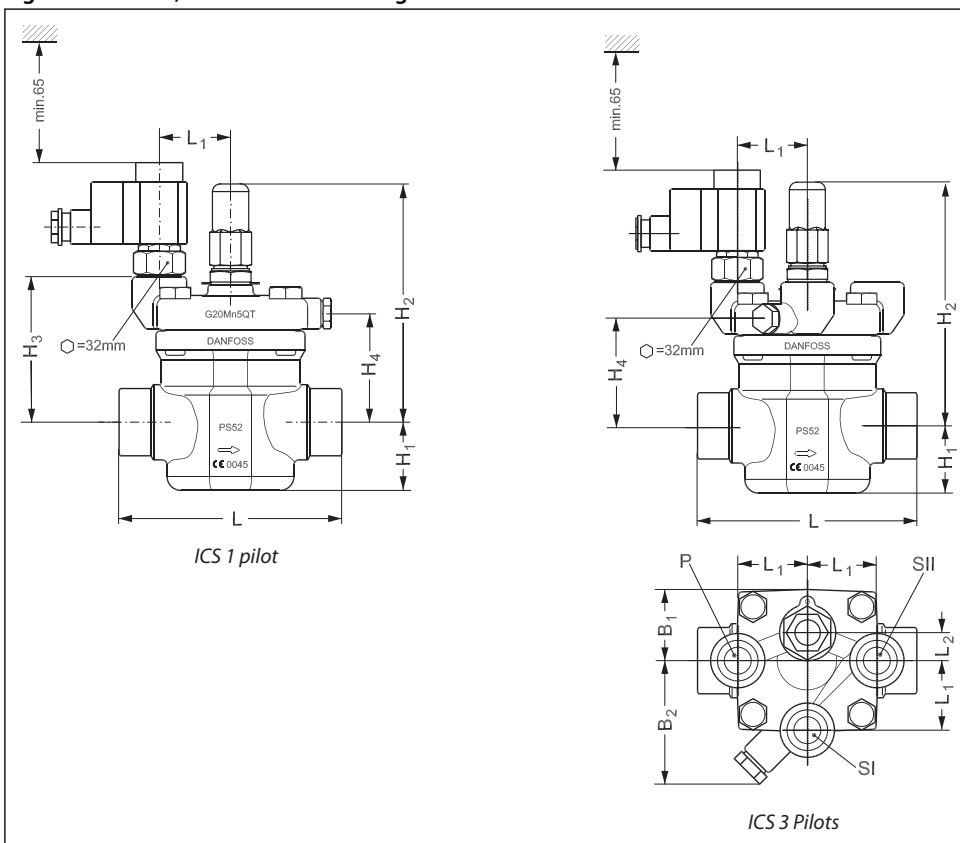

Pilot-operated servo valve, type ICS

Table 18: Connection type and Weight

Connection		H <sub>1</sub>	H <sub>2</sub>	H <sub>3</sub>	H <sub>4</sub>	L	L <sub>1</sub>	L <sub>2</sub>	B <sub>1</sub>	B <sub>2</sub>	Weight ICS 1 Pilot	Weight ICS 3 Pilots
50 D (2 in.)	mm in.	59 2.32	181 7.13	120 4.72	93 3.66	200 7.87	51 2.00	15 0.59	63 2.48	91 3.58	8.9 kg 19.6 lb.	9.2 kg 20.2 lb.
65 D (2½ in.)	mm in.	59 2.32	181 7.13	120 4.72	93 3.66	210 8.27	51 2.00	15 0.59	63 2.48	91 3.58	8.9 kg 19.6 lb.	9.2 kg 20.2 lb.
50 A (2 in.)	mm in.	59 2.32	181 7.13	120 4.72	93 3.66	200 7.87	51 2.00	15 0.59	63 2.48	91 3.58	8.9 kg 19.6 lb.	9.2 kg 20.2 lb.
65 A (2½ in.)	mm in.	59 2.32	181 7.13	120 4.72	93 3.66	210 8.27	51 2.00	15 0.59	63 2.48	91 3.58	8.9 kg 19.6 lb.	9.2 kg 20.2 lb.
50 SOC (2 in.)	mm in.	59 2.32	181 7.13	120 4.72	93 3.66	216 8.50	51 2.00	15 0.59	63 2.48	91 3.58	8.9 kg 19.6 lb.	9.2 kg 20.2 lb.
54 SD (2½ in. SA)	mm in.	59 2.32	181 7.13	120 4.72	93 3.66	216 8.50	51 2.00	15 0.59	63 2.48	91 3.58	8.9 kg 19.6 lb.	9.2 kg 20.2 lb.

**NOTE:**

Specified weights are approximate values only.

**D** = Butt-weld DIN

**A** = Butt-weld ANSI

**J** = Butt-weld JIS

**SOC** = Socket weld ANSI

**SD** = Solder DIN

**SA** = Solder ANSI

**FPT** = Female Pipe Thread

ICS 65/ ICS 80

Figure 24: ICS 65 / ICS 80, Dimensions and weights

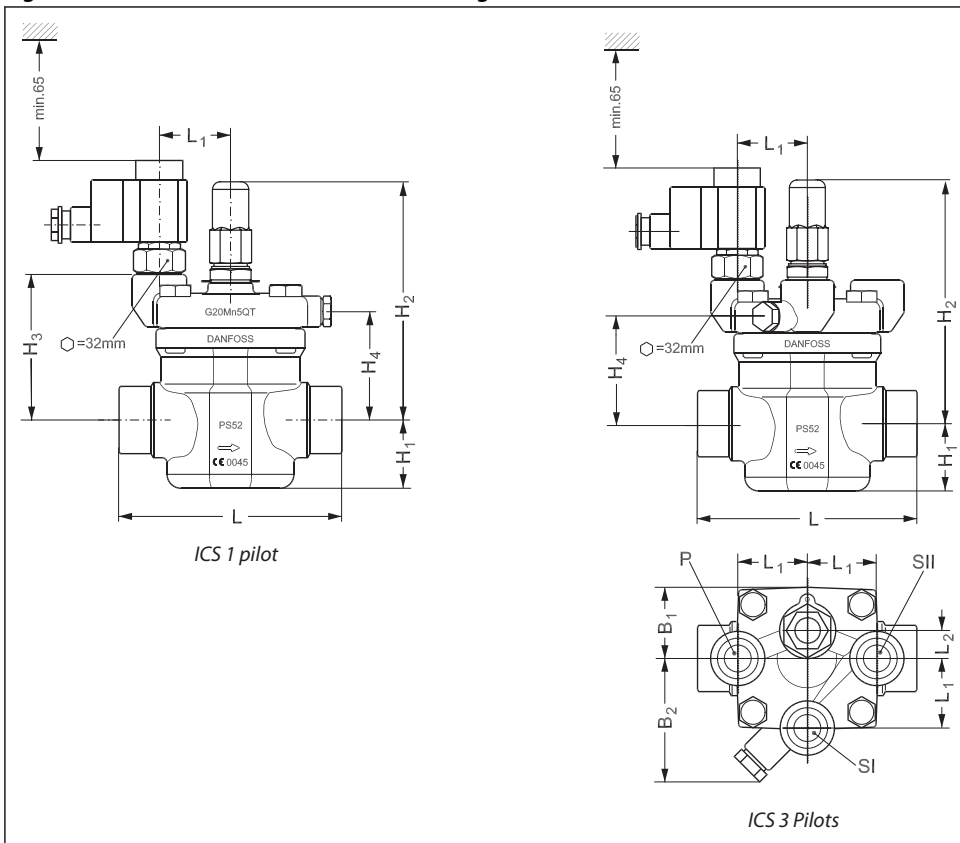

**Table 19: Connection type and Weight**

Connection		H <sub>1</sub>	H <sub>2</sub>	H <sub>3</sub>	H <sub>4</sub>	L	L <sub>1</sub>	L <sub>2</sub>	B <sub>1</sub>	B <sub>2</sub>	Weight ICS 1 Pilot	Weight ICS 3 Pilots
65 D (2½ in.)	mm in.	65 2.56	202 7.95	140 5.51	115 4.53	230 9.06	51 2.00	15 0.59	70 2.76	91 3.58	13.4 kg 29.48 lb.	13.5 kg 29.7 lb.
80 D (3 in.)	mm in.	65 2.56	202 7.95	140 5.51	115 4.53	245 9.65	51 2.00	15 0.59	70 2.76	91 3.58	13.4 kg 29.48 lb.	13.5 kg 29.7 lb.
65 A (2½ in.)	mm in.	65 2.56	202 7.95	140 5.51	115 4.53	230 9.06	51 2.00	15 0.59	70 2.76	91 3.58	13.4 kg 29.48 lb.	13.5 kg 29.7 lb.
80 A (3 in.)	mm in.	65 2.56	202 7.95	140 5.51	115 4.53	245 9.65	51 2.00	15 0.59	70 2.76	91 3.58	13.4 kg 29.48 lb.	13.5 kg 29.7 lb.
65 J (2½ in.)	mm in.	65 2.56	202 7.95	140 5.51	115 4.53	230 9.06	51 2.00	15 0.59	70 2.76	91 3.58	13.4 kg 29.48 lb.	13.5 kg 29.7 lb.
65 SOC (2½ in.)	mm in.	65 2.56	202 7.95	140 5.51	115 4.53	230 9.06	51 2.00	15 0.59	70 2.76	91 3.58	13.4 kg 29.48 lb.	13.5 kg 29.7 lb.
76 SD (3 in.)	mm in.	65 2.56	202 7.95	140 5.51	115 4.53	245 9.65	51 2.00	15 0.59	70 2.76	91 3.58	13.4 kg 29.48 lb.	13.5 kg 29.7 lb.
67 SA (2¾ in.)	mm in.	65 2.56	202 7.95	140 5.51	115 4.53	245 9.65	51 2.00	15 0.59	70 2.76	91 3.58	13.4 kg 29.48 lb.	13.5 kg 29.7 lb.

**NOTE:**

Specified weights are approximate values only.

**D** = Butt-weld DIN

**A** = Butt-weld ANSI

**J** = Butt-weld JIS

**SOC** = Socket weld ANSI

**SD** = Solder DIN

**SA** = Solder ANSI

**FPT** = Female Pipe Thread

## ICS 100

Figure 25: ICS 100, Dimensions and weights

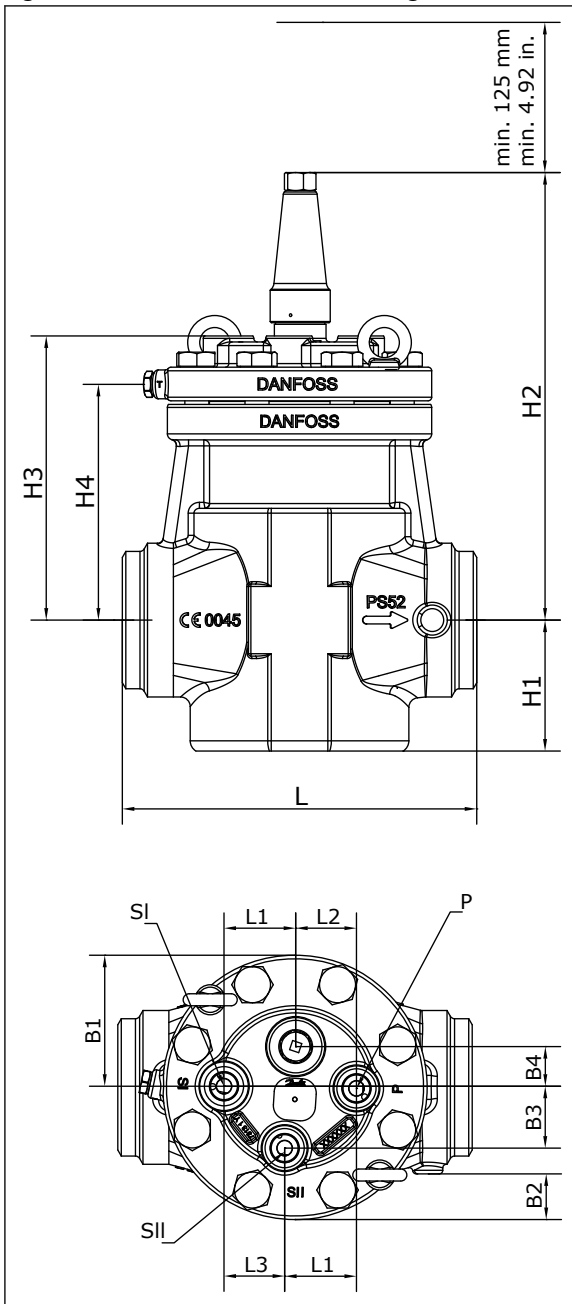

Table 20: Connection type and Weight

Connection		H <sub>1</sub>	H <sub>2</sub>	H <sub>3</sub>	H <sub>4</sub>	L	L <sub>1</sub>	L <sub>2</sub>	L <sub>3</sub>	B <sub>1</sub>	B <sub>2</sub>	B <sub>3</sub>	B <sub>4</sub>	Weight
100 D or A (4 in.)	mm	109	372	237	196	295	60	51	50	109	38	52	33	45 kg
	in.	4.3	14.7	9.3	7.7	11.6	2.4	2.0	2.0	4.3	1.5	2.1	1.3	99.2 lb.

**NOTE:**

Specified weights are approximate values only.

**D** = Butt-weld DIN ; **A** = Butt-weld ANSI

ICS 125

Figure 26: ICS 125, Dimensions and weights

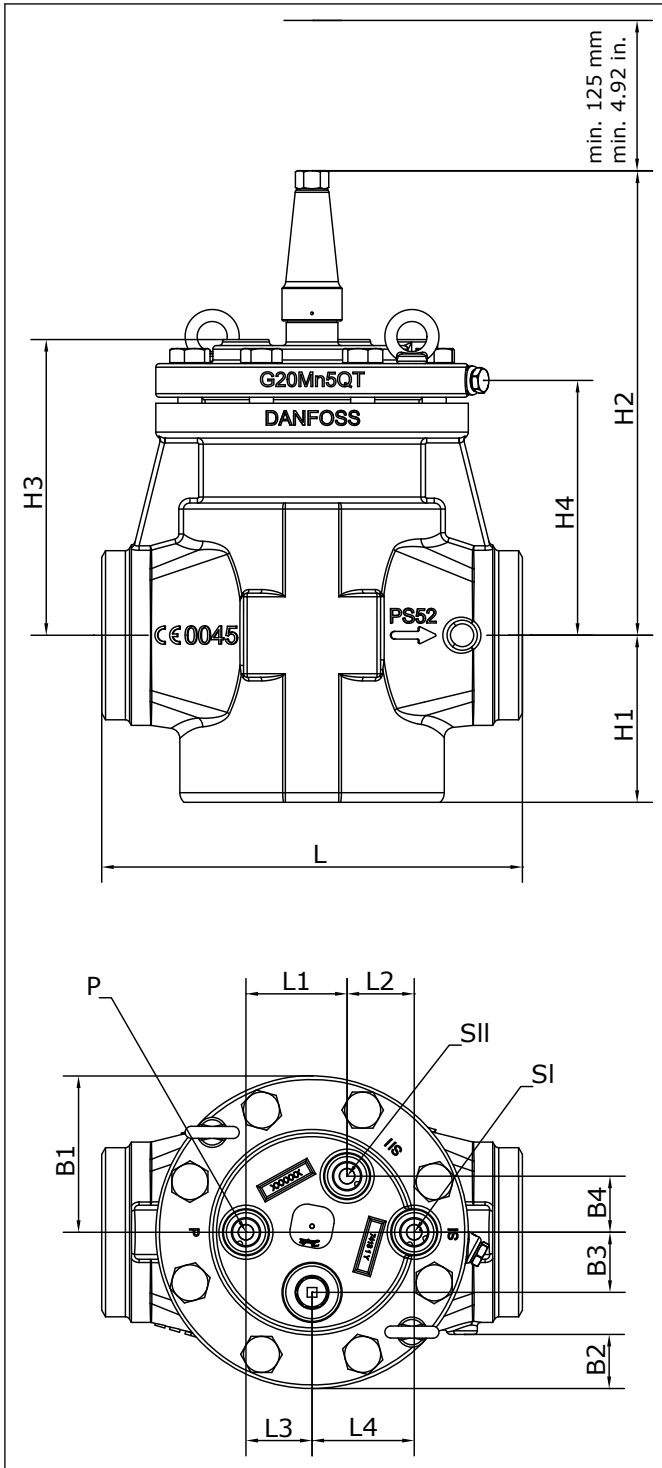

Table 21: Connection type and Weight

Connection	H <sub>1</sub>	H <sub>2</sub>	H <sub>3</sub>	H <sub>4</sub>	L	L <sub>1</sub>	L <sub>2</sub>	L <sub>3</sub>	L <sub>4</sub>	B <sub>1</sub>	B <sub>2</sub>	B <sub>3</sub>	B <sub>4</sub>	Weight	
125 D or A (5 in.)	mm in.	139 5.5	386 15.2	246 9.7	212 8.4	350 13.8	84 3.3	56 2.2	55 2.2	85 3.4	130 5.1	45 1.8	50 2.0	47 1.9	68 kg 149.9 lb.

**NOTE:**

Specified weights are approximate values only.

**D** = Butt-weld DIN ; **A** = Butt-weld ANSI

ICS 150

Figure 27: ICS 150, Dimensions and weights

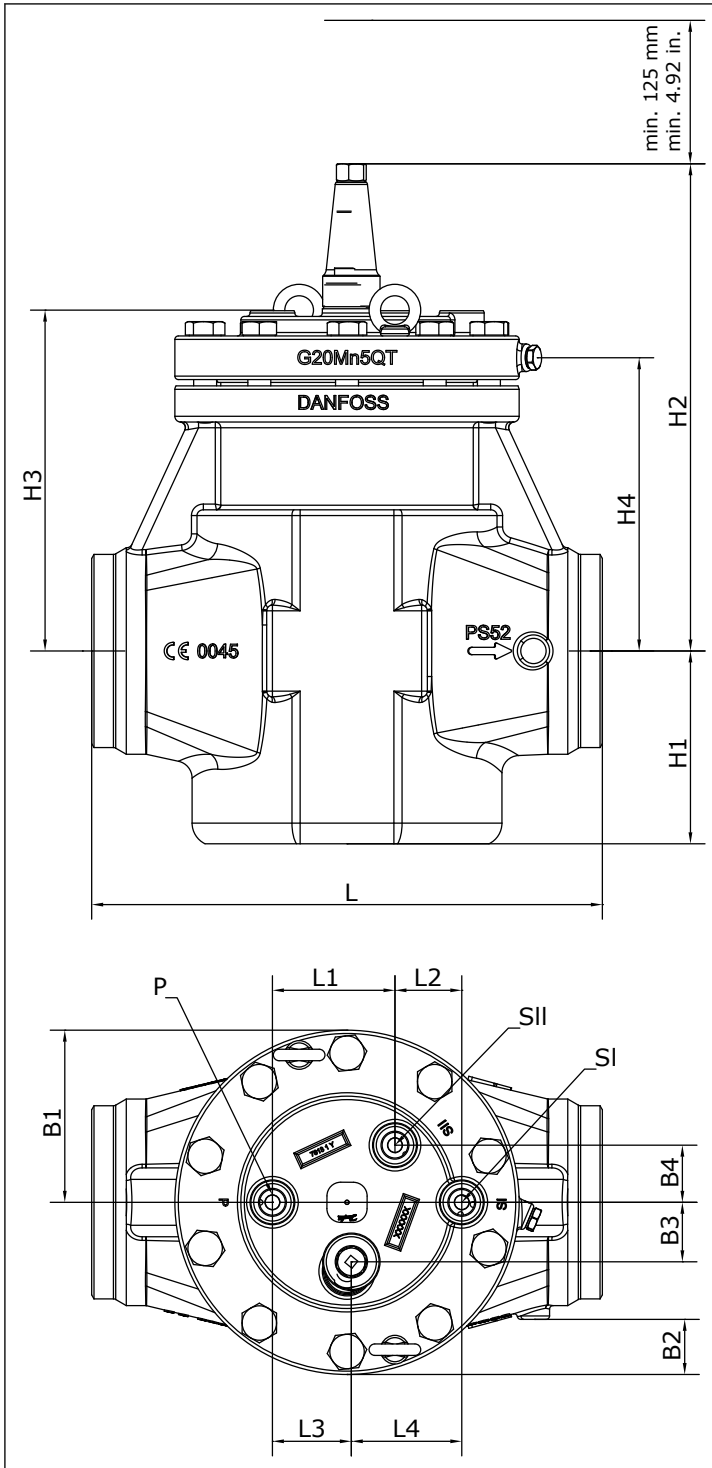

Table 22: Connection type and Weight

Connection		H <sub>1</sub>	H <sub>2</sub>	H <sub>3</sub>	H <sub>4</sub>	L	L <sub>1</sub>	L <sub>2</sub>	L <sub>3</sub>	L <sub>4</sub>	B <sub>1</sub>	B <sub>2</sub>	B <sub>3</sub>	B <sub>4</sub>	Weight
150 D or A (6 in.)	mm in.	168 6.6	425 16.7	297 11.7	256 10.1	445 17.5	107 4.2	58 2.3	69 2.7	96 3.8	150 5.9	48 1.9	52 2.1	50 2.0	115 kg 253.5 lb.

**NOTE:**

Specified weights are approximate values only.

**D** = Butt-weld DIN ; **A** = Butt-weld ANSI

**Ordering**

**ICS 25**

**Ordering from the parts programme**

Figure 28: Example (select from table ICV 25 valve body w/different connections, table ICS 25 function module and table ICS 25 top cover)

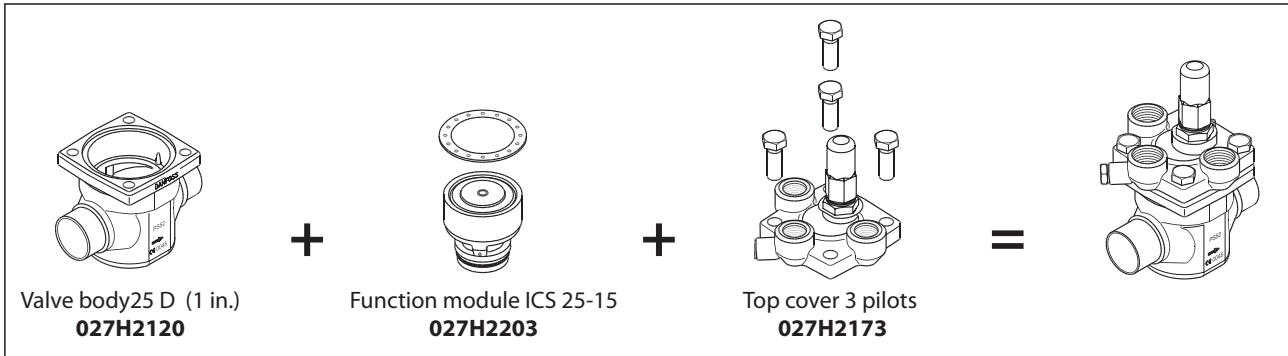

Figure 29: ICV 25 valve body

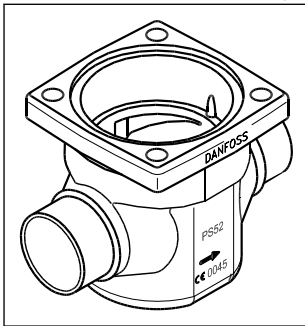

Table 23: ICV 25 valve body w/different connections

Connection	Code Number
20 D (3/4 in.)	027H2128
25 D (1 in.)	027H2120
32 D (1 1/4 in.)	027H2129
40 D (1 1/2 in.)	027H2135
35 SD (13/8 in. SA)	027H2134
28 SA (1 1/8 in.)	027H2126
22 SA (7/8 in.)	027H2125
28 SD (1 1/8 in.)	027H2124
22 SD (7/8 in.)	027H2123
20 A (3/4 in.)	027H2131
25 A (1 in.)	027H2121
32 A (1 1/4 in.)	027H2130
20 SOC (3/4 in.)	027H2132
25 SOC (1 in.)	027H2122
20 FPT (1/2 in.)	027H2133
25 FPT (1 in.)	027H2127

- D** = Butt-weld DIN
- A** = Butt-weld ANSI
- J** = Butt-weld JIS
- SOC** = Socket weld ANSI
- SD** = Solder DIN
- SA** = Solder ANSI
- FPT** = Female Pipe Thread

## Pilot-operated servo valve, type ICS

Figure 30: ICS 25 function module

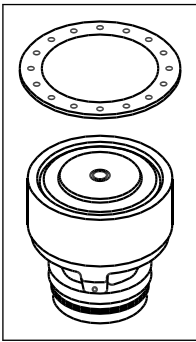

Table 24: ICS 25 function module

Description	Code Number
ICS 25-5	027H2201 <sup>(1)</sup>
ICS 25-10	027H2202 <sup>(1)</sup>
ICS 25-15	027H2203 <sup>(1)</sup>
ICS 25-20	027H2204 <sup>(1)</sup>
ICS 25-25	027H2200 <sup>(1)</sup>

<sup>(1)</sup> Including gasket and O-rings

Figure 31: ICS 1

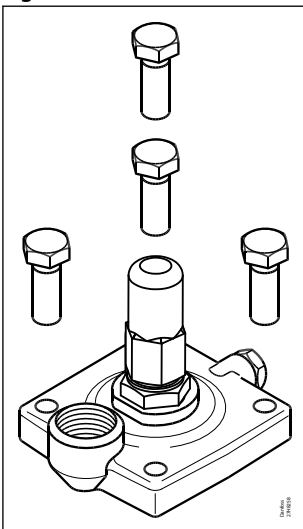

Figure 32: ICS 3

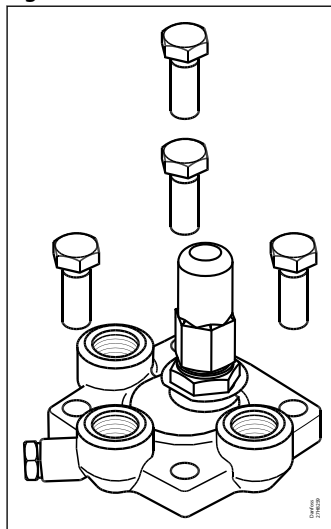

Table 25: ICS 25 top cover

Description	Code Number
Top cover 1 Pilot	027H2172 <sup>(2)</sup>
Top cover 3 Pilots	027H2173 <sup>(3)</sup>

<sup>(2)</sup> Including bolts

<sup>(3)</sup> including bolts and one blanking plug

### Ordering complete factory assembled valve

(body, function module and top cover)

## Pilot-operated servo valve, type ICS

Figure 33: 1 pilot

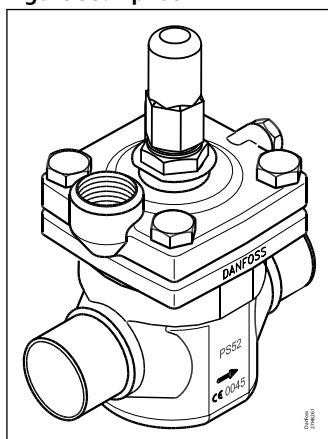

Figure 34: 3 pilots

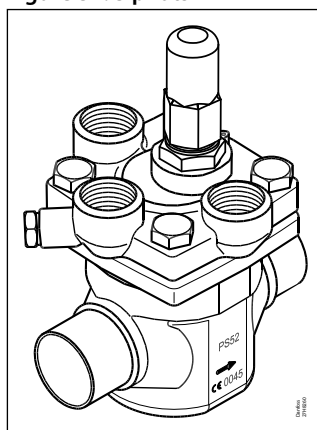

Table 26: Connections

		Available connections							
		20 D (¾ in.)	25 D (1 in.)	32 D (1¼ in.)	40 D (1½ in.)	35 SD (1⅜ in. SA)	28 SA (1⅞ in.)	22 SA (⅞ in.)	28 SD (1⅞ in.)
ICS 25-5	1 Pilot	027H2028	027H2020	*	*	*	027H2026	027H2025	027H2024
	3 Pilots <sup>(4)</sup>	027H2078	027H2070	*	*	*	027H2076	027H2075	027H2074
ICS 25-10	1 Pilot	027H2038	027H2030	*	*	*	027H2036	027H2035	027H2034
	3 Pilots <sup>(4)</sup>	027H2088	027H2080	*	*	*	027H2086	027H2085	027H2084
ICS 25-15	1 Pilot	027H2048	027H2040	*	*	*	027H2046	027H2045	027H2044
	3 Pilots <sup>(4)</sup>	027H2098	027H2090	*	*	*	027H2096	027H2095	027H2094
ICS 25-20	1 Pilot	027H2058	027H2050	*	*	*	027H2056	027H2055	027H2054
	3 Pilots <sup>(4)</sup>	027H2108	027H2100	*	*	*	027H2106	027H2105	027H2104
ICS 25-25	1 Pilot	027H2068	027H2060	*	*	*	027H2066	027H2065	027H2064
	3 Pilots <sup>(4)</sup>	027H2118	027H2110	*	*	*	027H2116	027H2115	027H2114

<sup>(4)</sup> Including one blanking plug (A+B)

\* Select from parts programme

Table 27: Connections

		Available connections							
		22 SD (⅞ in.)	20 A (¾ in.)	25 A (1 in.)	32 A (1¼ in.)	20 SOC (¾ in.)	25 SOC (1 in.)	20 FPT (½ in.)	25 FPT (1 in.)
ICS 25-5	1 Pilot	027H2023	027H2029	027H2021	*	027H2140	*	*	*
	3 Pilots <sup>(4)</sup>	027H2073	027H2079	027H2071	*	027H2145	*	*	*
ICS 25-10	1 Pilot	027H2033	027H2039	027H2031	*	*	*	*	*
	3 Pilots <sup>(4)</sup>	027H2083	027H2089	027H2081	*	027H2146	*	*	*
ICS 25-15	1 Pilot	027H2043	027H2049	027H2041	*	027H2142	*	*	*
	3 Pilots <sup>(4)</sup>	027H2093	027H2099	027H2091	*	*	*	*	*
ICS 25-20	1 Pilot	027H2053	027H2059	027H2051	*	027H2143	*	*	*
	3 Pilots <sup>(4)</sup>	027H2103	027H2109	027H2101	*	027H2148	*	*	*
ICS 25-25	1 Pilot	027H2063	*	027H2061	*	*	027H2062	*	*
	3 Pilots <sup>(4)</sup>	027H2113	*	027H2111	*	*	027H2112	*	*

\* Select from parts programme

## ICS 32

### Ordering from the parts programme

Figure 35: Example (select from table ICV 32 valve body w/different connections, table ICS 32 function module and table ICS 32 top cover)

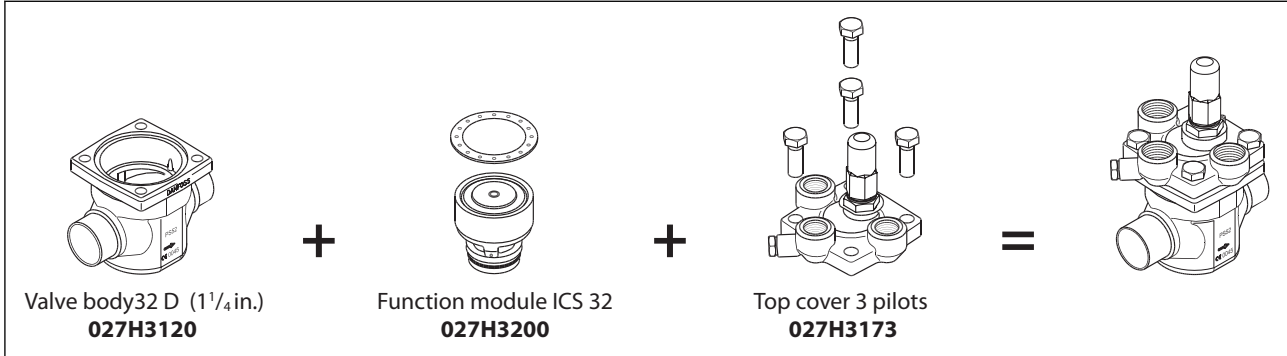

Figure 36: ICV 32 valve body w/different connections

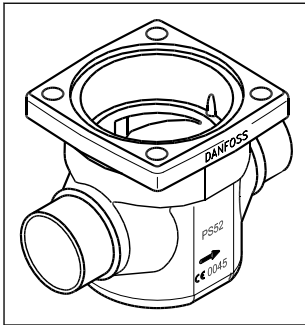

Table 28: ICV 32 valve body w/different connections

Connections	Code Number
32 D (1 1/4 in.)	027H3120
40 D (1 1/2 in.)	027H3125
42 SA (1 3/8 in.)	027H3127
42 SD (1 3/8 in.)	027H3128
35 SD (1 3/8 in. SA)	027H3123
32 A (1 1/4 in.)	027H3121
32 SOC (1 1/4 in.)	027H3122
40 A (1 1/2 in.)	027H3126

**D** = Butt-weld DIN

**A** = Butt-weld ANSI

**J** = Butt-weld JIS

**SOC** = Socket weld ANSI

**SD** = Solder DIN

**SA** = Solder ANSI

**FPT** = Female Pipe Thread

Figure 37: function module

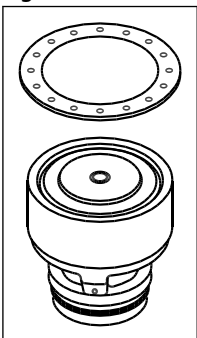

## Pilot-operated servo valve, type ICS

**Table 29: ICS 32 function module**

Description	Code Number
ICS 32	027H3200 <sup>(1)</sup>

<sup>(1)</sup> Including gasket and O-rings

**Figure 38: ICS 1**

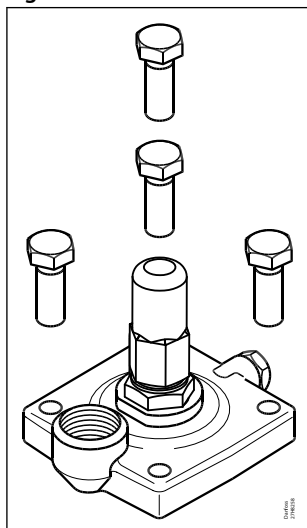

**Figure 39: ICS 3**

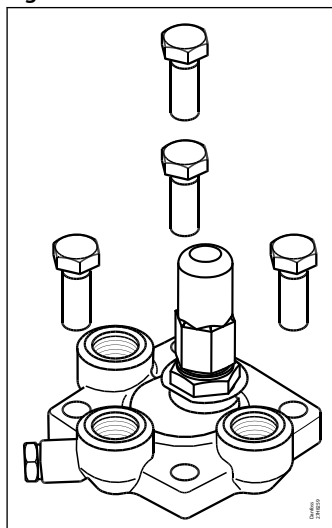

**Table 30: ICS 32 top cover**

Description	Code Number
Top cover 1 Pilot	027H3172 <sup>(2)</sup>
Top cover 3 Pilots	027H3173 <sup>(3)</sup>

<sup>(2)</sup> Including bolts

<sup>(3)</sup> Including bolts and one blanking plug

### Ordering complete factory assembled valve

(body, function module and top cover)

**Figure 40: 1 pilot**

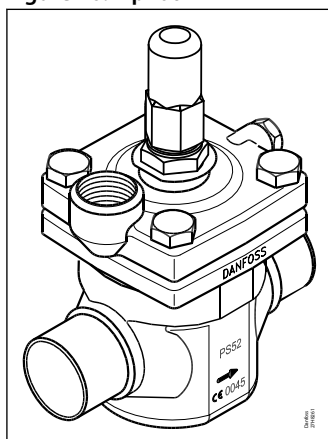

**Figure 41: 3 pilots**

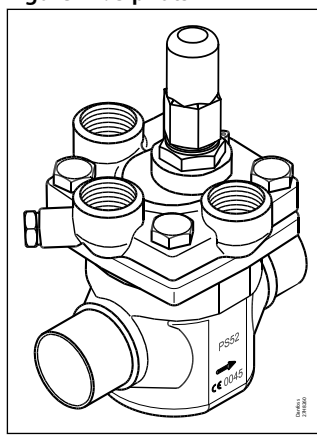

**Table 31: Connections**

		Available connections							
		32 D (1¼ in.)	40 D (1½ in.)	42 SA (1⅝ in.)	42 SD (1⅝ in.)	35 SD (1⅝ in. SA)	32 A (1¼ in.)	32 SOC (1¼ in.)	40 A (1½ in.)
ICS 32	1 Pilot	027H3020	*	*	*	027H3023	027H3021	027H3022	*
	3 Pilots <sup>(4)</sup>	027H3030	*	*	*	027H3033	027H3031	027H3032	*

<sup>(4)</sup> Including one blanking plug (A+B)

\* Select from parts programme

## ICS 40

### Ordering from the parts programme

Figure 42: Example (select from table ICV 40 valve body w/different connections, table ICS 40 function module and table ICS 40 top cover)

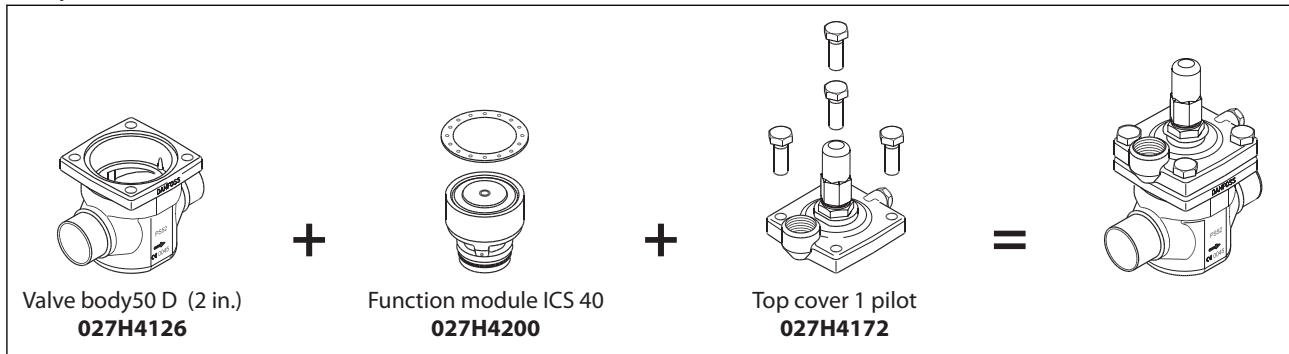

Figure 43: ICV 40 valve body w/different connections

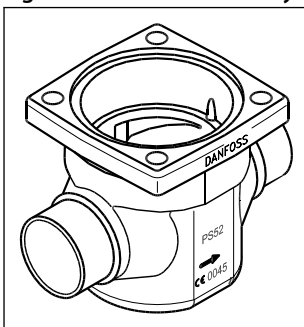

Table 32: ICV 40 valve body w/different connections

Connections	Code Number
40 D (1½ in.)	027H4120
50 D (2 in.)	027H4126
42 SA (1¾ in.)	027H4124
42 SD (1¾ in.)	027H4123
40 A (1½ in.)	027H4121
40 SOC (1½ in.)	027H4122
50 A (2 in.)	027H4127

**D** = Butt-weld DIN

**A** = Butt-weld ANSI

**J** = Butt-weld JIS

**SOC** = Socket weld ANSI

**SD** = Solder DIN

**SA** = Solder ANSI

**FPT** = Female Pipe Thread

Figure 44: function module

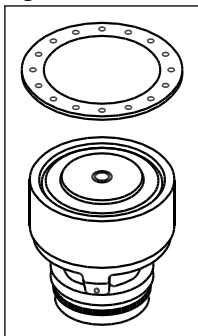

## Pilot-operated servo valve, type ICS

**Table 33: ICS 40 function module**

Description	Code Number
ICS 40	027H4200 <sup>(1)</sup>

<sup>(1)</sup> Including gasket and O-rings

**Figure 45: ICS 1**

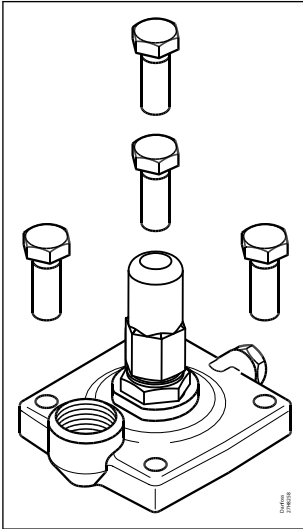

**Figure 46: ICS 3**

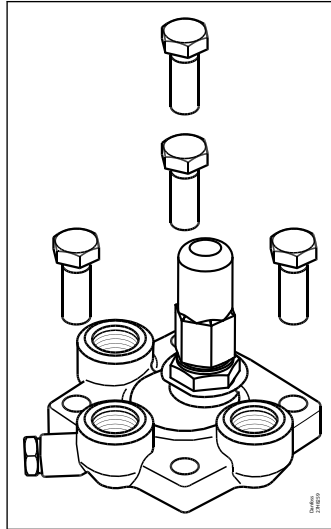

**Table 34: ICS 40 top cover**

Description	Code Number
Top cover 1 Pilot	027H4172 <sup>(2)</sup>
Top cover 3 Pilots	027H4173 <sup>(3)</sup>

<sup>(2)</sup> Including bolts

<sup>(3)</sup> Including bolts and one blanking plug

### Ordering complete factory assembled valve

(body, function module and top cover)

**Figure 47: 1 pilot**

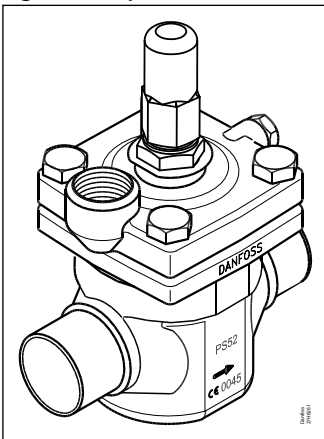

**Figure 48: 3 pilots**

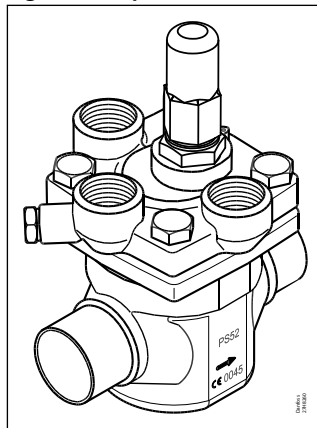

**Table 35: Connections**

		Available connections						
		40 D (1½ in.)	50 D (2 in.)	42 SA (1⅝ in.)	42 SD (1⅝ in.)	40 A (1½ in.)	40 SOC (1½ in.)	50 A (2 in.)
ICS 32	1 Pilot	027H4020	*	027H4024	027H4023	027H4021	027H4022	*
	3 Pilots <sup>(4)</sup>	027H4030	*	027H4034	027H4033	027H4031	027H4032	*

<sup>(4)</sup> Including one blanking plug (A+B)

\* Select from parts programme

## ICS 50

### Ordering from the parts programme

Figure 49: Example (select from table ICV 50 valve body w/different connections, table ICS 50 function module and table ICS 50 top cover)

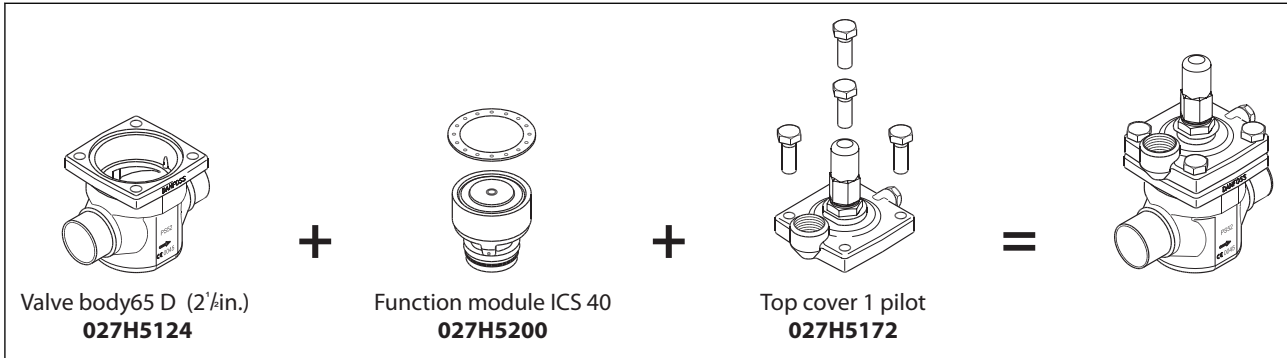

Figure 50: ICV 50 valve body w/different connections

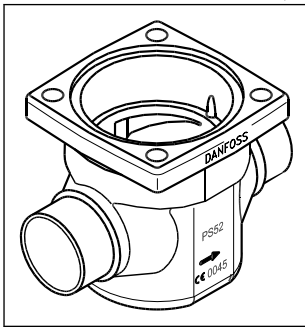

Table 36: ICV 50 valve body w/different connections

Connections	Code Number
50 D (2 in.)	027H5120
65 D (2 1/2 in.)	027H5124
54 SD (2 1/8 in. SA)	027H5123
50 A (2 in.)	027H5121
50 SOC (2 in.)	027H5122
65 A (2 1/2 in.)	027H5125

**D** = Butt-weld DIN

**A** = Butt-weld ANSI

**J** = Butt-weld JIS

**SOC** = Socket weld ANSI

**SD** = Solder DIN

**SA** = Solder ANSI

**FPT** = Female Pipe Thread

Figure 51: function module

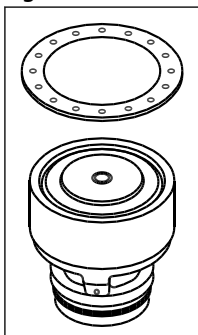

## Pilot-operated servo valve, type ICS

**Table 37: ICS 50 function module**

Description	Code Number
ICS 50	027H5200 <sup>(1)</sup>

<sup>(1)</sup> Including gasket and O-rings

**Figure 52: ICS 1**

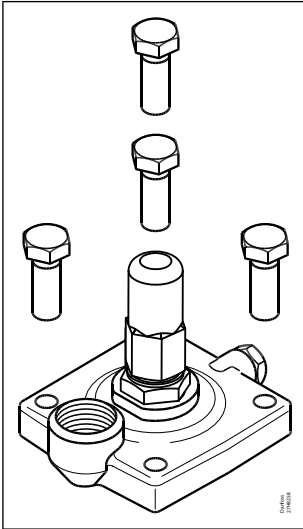

**Figure 53: ICS 3**

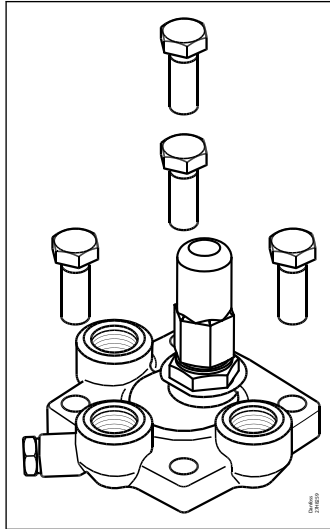

**Table 38: ICS 50 top cover**

Description	Code Number
Top cover 1 Pilot	027H5172 <sup>(2)</sup>
Top cover 3 Pilots	027H5173 <sup>(3)</sup>

<sup>(2)</sup> Including bolts

<sup>(3)</sup> Including bolts and one blanking plug

### Ordering complete factory assembled valve

(body, function module and top cover)

**Figure 54: 1 pilot**

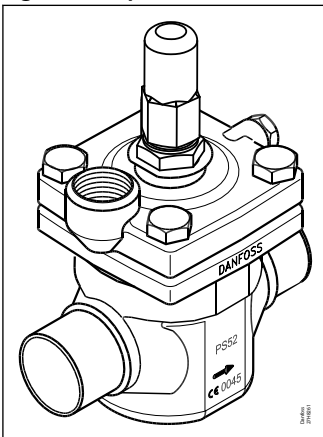

**Figure 55: 3 pilots**

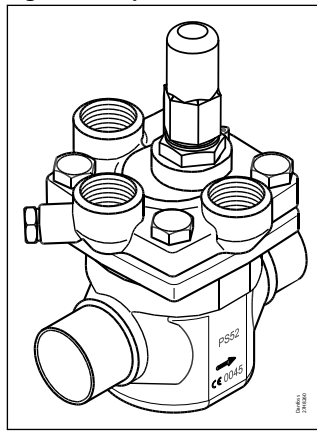

**Table 39: Connections**

		Available connections					
		50 D (2 in.)	65 D (2½ in.)	54 SD (2⅞ in. SA)	65 A (2½ in.)	50 A (2 in.)	50 SOC (2 in.)
ICS 50	1 Pilot	027H5020	*	027H5023	*	027H5021	027H5022
	3 Pilots <sup>(4)</sup>	027H5030	*	027H5033	*	027H5031	027H5032

<sup>(4)</sup> Including one blanking plug (A+B)

\* Select from parts programme

## ICS 65 and ICS 80

### Ordering from the parts programme

Figure 56: Example (select from table ICV 65 valve body w/different connections, table ICS 65 and ICS 80 function module and table ICS 65/80 top cover)

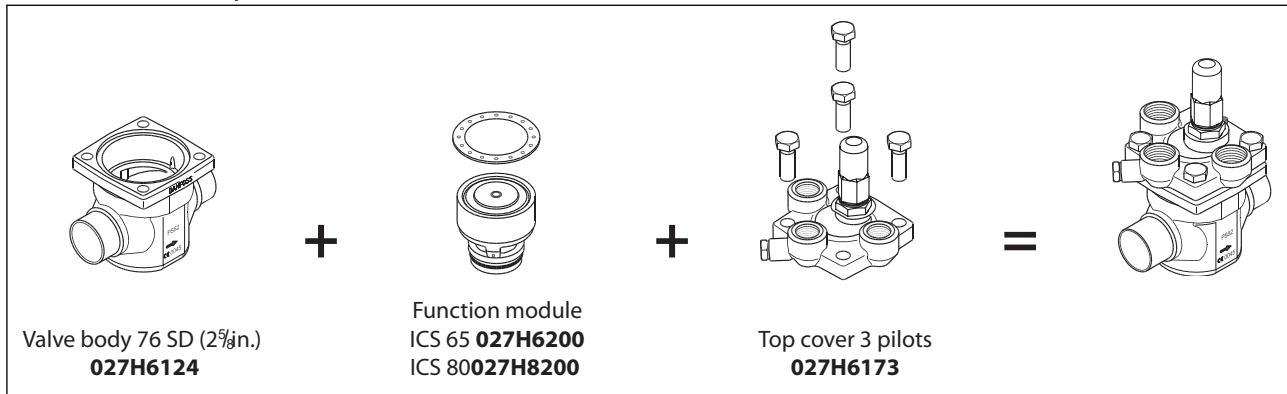

Figure 57: ICV 65 valve body w/different connections

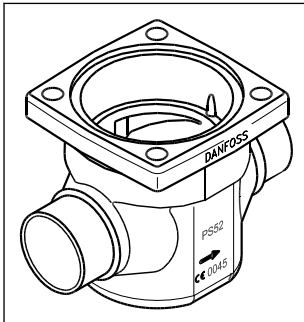

Table 40: ICV 65 valve body w/different connections

Connections	Code Number
65 D (2 1/2 in.)	027H6120
65 A (2 1/2 in.)	027H6121
65 J (2 1/2 in.)	027H6122
80 D (3 in.)	027H6126
80 A (3 in.)	027H6127
67 SA (2 3/8 in.)	027H6125
76 SD (3 in.)	027H6124
65 SOC (2 1/2 in.)	027H6123

**D** = Butt-weld DIN

**A** = Butt-weld ANSI

**J** = Butt-weld JIS

**SOC** = Socket weld ANSI

**SD** = Solder DIN

**SA** = Solder ANSI

**FPT** = Female Pipe Thread

## Pilot-operated servo valve, type ICS

Figure 58: function module

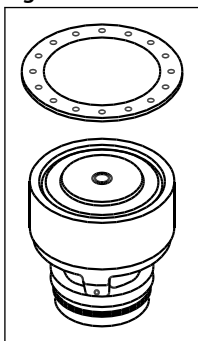

Table 41: ICS 65 and ICS 80 function module

Description	Code Number
ICS 65	027H6200 <sup>(1)</sup>
ICS 80	027H8200 <sup>(1)</sup>

<sup>(1)</sup> Including gasket and O-rings

Figure 59: ICS 1

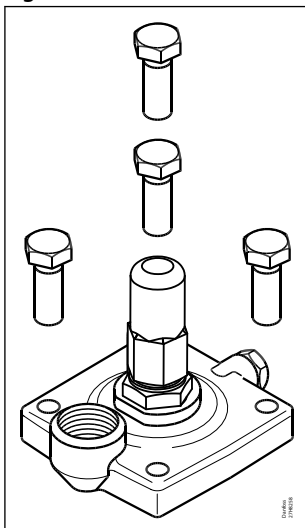

Figure 60: ICS 3

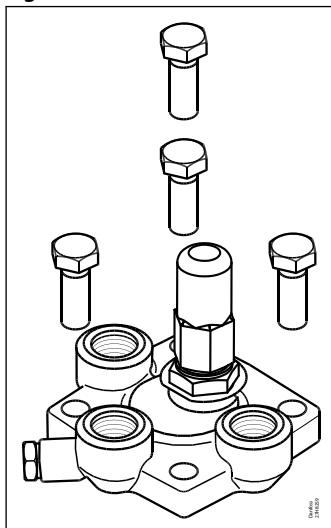

Table 42: ICS 65/80 top cover

Description	Code Number
Top cover 1 Pilot (65)	027H6172 <sup>(2)</sup>
Top cover 3 Pilots (65)	027H6173 <sup>(3)</sup>
Top cover 1 Pilot (80)	027H8192 <sup>(2)</sup>
Top cover 3 Pilots (80)	027H8193 <sup>(3)</sup>

<sup>(2)</sup> Including bolts

<sup>(3)</sup> Including bolts and one blanking plug

**Ordering complete factory assembled valve**  
(body, function module and top cover)

## Pilot-operated servo valve, type ICS

Figure 61: 1 pilot

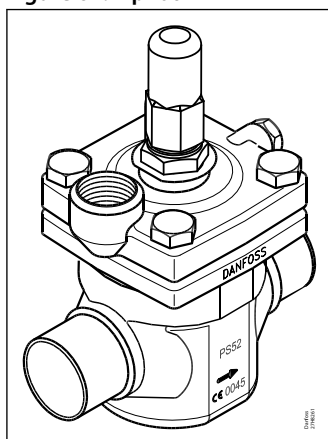

Figure 62: 3 pilots

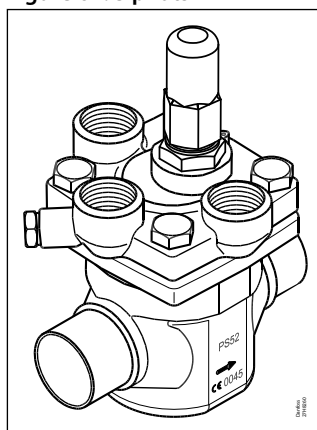

Table 43: Connections

		Available connections							
		65 D (2½ in.)	65 A (2½ in.)	65 SOC (2½ in.)	80 D (3 in.)	80 A (3 in.)	67 SA (2⅝ in.)	76 SD (3 in.)	65 J (2½ in.)
ICS 50	1 Pilot	027H6020	027H6021	027H6023	*	*	027H6025	027H6024	*
	3 Pilots <sup>(4)</sup>	027H6030	027H6021	027H6033	*	*	027H6035	027H6034	*
ICS 80	1 Pilot	*	*	*	027H8020	027H8021	*	*	*
	3 Pilots <sup>(4)</sup>	*	*	*	027H8030	027H8031	*	*	*

<sup>(4)</sup> Including one blanking plug (A+B)

\* Select from parts programme

**NOTE:**

The capacity of the ICS 80 module can only be achieved when using the valve body with 80 D or A (3 in.) connections.

If any other ICV 65 valve body is used the capacity of the complete valve will be reduced by approximately 6%.

## ICS 100 - 150

### Ordering complete factory assembled valve

(body, function module and top cover)

Figure 63: ICS 100

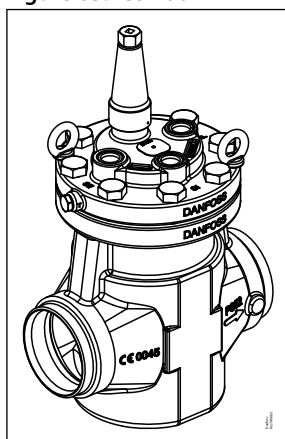

Table 44: Connections

	Connections		
	100 D (4 in.)	100 A (4 in.)	100 A (4 in.) with ⅜ in. NPT pressure outlet
ICS 100 <sup>(1)</sup>	027H7120	027H7121	027H7122

<sup>(1)</sup> Including two blanking plugs (A) and one sealing plug (B)

Pilot-operated servo valve, type ICS

Figure 64: ICS 125

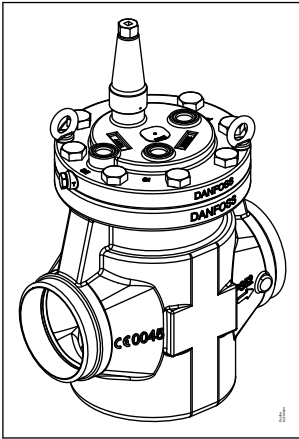

Table 45: Connections

	Connections		
	125 D (5 in.)	125 A (5 in.)	125 A (5 in.) with 3/8 in. NPT pressure outlet
ICS 125 <sup>(1)</sup>	027H7140	027H7141	027H7142

Figure 65: ICS 150

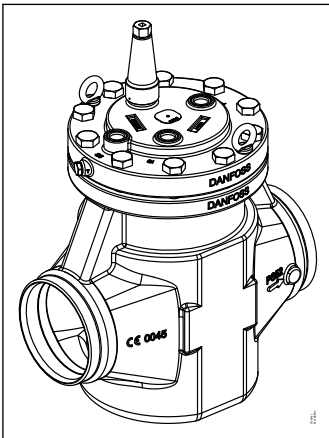

Table 46: Connections

	Connections		
	150 D (6 in.)	150 A (6 in.)	150 A (6 in.) with 3/8 in. NPT pressure outlet
ICS 150 <sup>(1)</sup>	027H7160	027H7161	027H7162

**Spare parts:** Please see AI245486497115

**Accessories**

Figure 66: Top cover

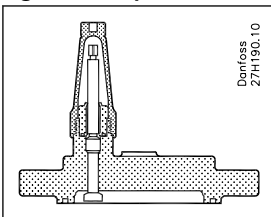

## Pilot-operated servo valve, type ICS

**Table 47: Top covers**

Top covers		
	Size	Code number
Consist of: Top cover complete with manual spindle, and gasket	ICS 100	027H7123
	ICS 125	027H7143
	ICS 150	027H7163

### ICV PM flanged valve housings

ICV PM flanged valve housings can replace the PM valves on already installed refrigeration systems.

**Figure 67: ICV PM flanged valve housing**

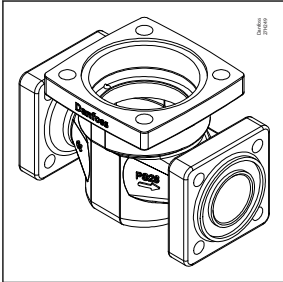

### Pressure range

The ICV PM valve housing is designed for a max. working pressure of 28 bar (406 psig) and therefore a suitable replacement for PM valves in the service market. They also offer the same drop-in dimensions as the PM valves.

**Table 48: Top covers**

Description	Code no.
ICV 25 PM Valve housing	027H2119 <sup>(1)</sup>
ICV 32 PM Valve housing	027H3129 <sup>(1)</sup>
ICV 40 PM Valve housing	027H4128 <sup>(1)</sup>
ICV 50 PM Valve housing	027H5127 <sup>(2)</sup>
ICV 65 PM Valve housing	027H6128 <sup>(2)</sup>

<sup>(1)</sup> Includes ICV PM valve housing, flange gaskets and flange bolts.

<sup>(2)</sup> Includes ICV PM valve housing, flange gaskets, flange bolts and flange nuts.

Function modules and top covers must be ordered separately (see the section “**Ordering**”).

**Figure 68: ICV PM**

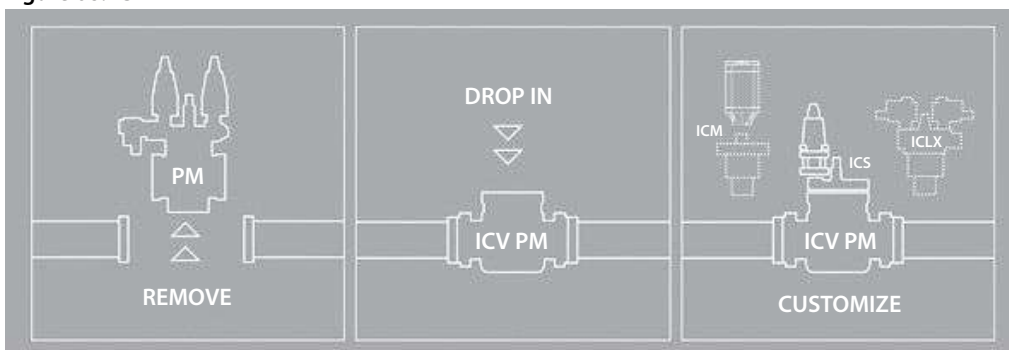

### ICV (H)A4A flanged valve housings

ICV (H)A4A flanged valve housings can replace the (H)A4A valves on already installed refrigeration systems.

## Pilot-operated servo valve, type ICS

Figure 69: ICV (H)A4A flanged valve housing

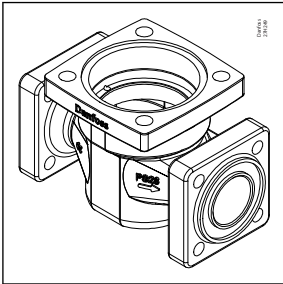

### Pressure range

The ICV (H)A4A valve housing is designed for a max. working pressure of 28 bar (406 psig) and therefore a suitable replacement for (H)A4A valves in the service market. They also offer the same drop-in dimensions as the (H)A4A valves.

Table 49: ICV Valve housing

Description	Code no.
ICV 25 (H)A4A Valve housing	027H2304 <sup>(3)</sup>
ICV 32 A4A Valve housing	027H3130
ICV 32 HA4A Valve housing	027H3131
ICV 40 (H)A4A Valve housing	027H4129
ICV 50 (H)A4A Valve housing	027H5128
ICV 65 (H)A4A Valve housing	027H6129

<sup>(3)</sup> Includes ICV (H)A4A valve housing, flange gaskets, flange bolts and flange nuts.

Function modules and top covers must be ordered separately (see the section “[Ordering](#)”).

Figure 70: ICV (H)A4A

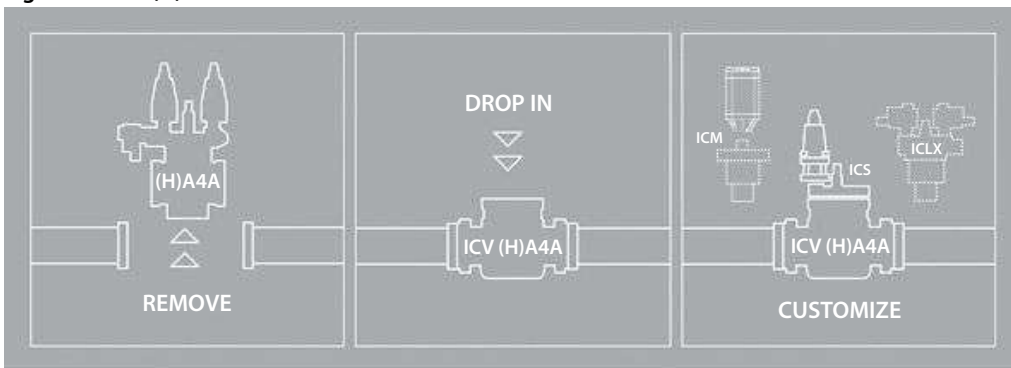

### Pressure gauge connection (weld / solder)

Figure 71: Pressure gauge connection (weld / solder).

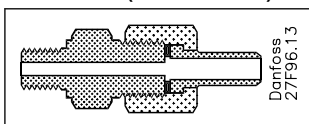

Table 50: Pressure gauge connection (weld / solder).

Description	Code no.
$\varnothing$ 6.5 mm / $\varnothing$ 10 mm ( $\varnothing$ 0.26 in. / $\varnothing$ 0.39 in.) weld / solder	027B2035

Figure 72: Pressure gauge connection (weld / solder)

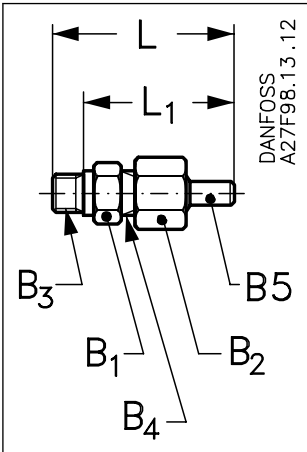

Table 51: Pressure gauge connection (weld / solder)

Accessories	size	L	L <sub>1</sub>	B <sub>1</sub>	B <sub>2</sub>	B <sub>3</sub>	B <sub>4</sub>	B <sub>5</sub>
	mm	66	54	AF 19	AF 22	G ¼ A	G ⅜ A	Ø6.5 / Ø10
	in.	2.60	2.13					

Pressure gauge connection, ¼ in. flare (self-closing)

Pressure gauge connection, ¼ in. flare (self-closing) Must not be used in R 717 plant.

Figure 73: ¼ in. flare (self-closing)

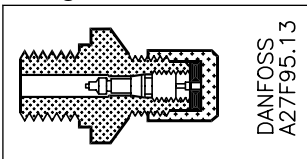

Table 52: Connection

Description	Code no.
¼ in. flare	027B2041

Figure 74: ¼ in. flare (self-closing)

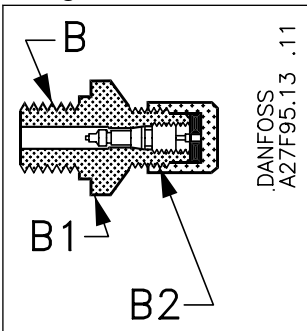

Table 53: Pressure gauge connection, ¼ in. flare (self-closing)

Accessories	B	B <sub>1</sub>	B <sub>2</sub>
¼ in. flare	G ¼ A	AF 19	¼ in. flare

## Pressure gauge connection (cutting ring)

Figure 75: Pressure gauge connection (cutting ring).

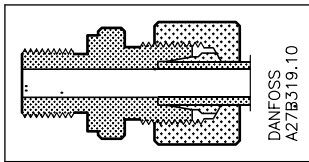

Table 54: Cutting ring connection

Description	Code no.
Cutting ring connection, 6 mm	027B2063
Cutting ring connection, 10 mm	027B2064

Figure 76: Cutting ring connection

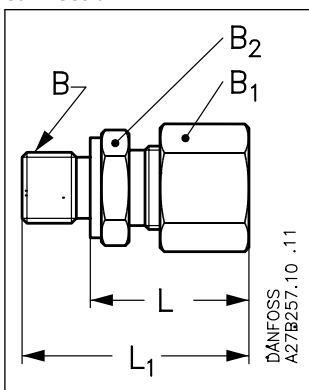

Table 55: Pressure gauge connection (cutting ring)

Accessories		L	L1	B	B1	B2
6 mm	mm in.	27 1.06	39 1.54	G ¼ A	AF 19	AF 14
10 mm	mm in.	29 1.14	40 1.57	G ¼ A	AF 19	AF 14

## Multi-function tool

Table 56: Multi-function tool

Description	Code no.
Multi-function tool for ICS 25-65	027H0180 / 027H0181

Figure 77: Multi-function tool



The multi-funktion tool can be used for:

- Removing the ICS function module
- Operating the manual spindle

For further information please see the instruction PIHU0A.

### Pressure gauge connection

Figure 78: Connection

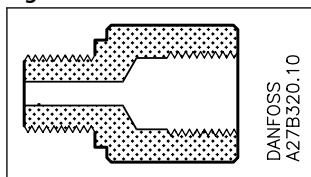

Table 57: Pressure gauge connection

Description	Code no.
¼ FPT	027B2062

Figure 79: Pressure gauge connection

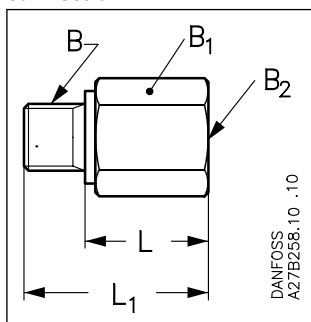

Table 58: Pressure gauge connection

Accessories		L	L <sub>1</sub>	B	B <sub>1</sub>	B <sub>2</sub>
	mm	23	35.5			
	in.	0.91	1.40	G ¼ A	AF 22	¼ FPT

### External pilot connection

Figure 80: Connection

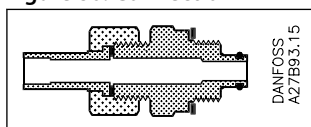
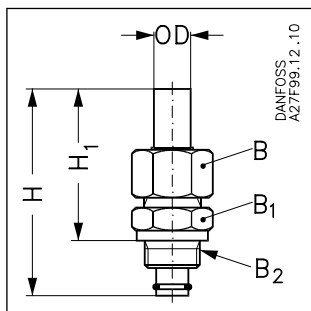

Table 59: ICS connections

ICS	Description	Code no.
5 - 80	External pilot connection (incl. damping orifice, D: 1.0 mm)	027F1048
5 - 150	Accessory bag with seal and O-ring for pilot valve	027F0666
100 - 150	External pilot connection (incl. damping orifice, D: 1.8 mm)	027F1049

Figure 81: External pilot connection



## Pilot-operated servo valve, type ICS

**Table 60: External pilot connection**

Accessories		H	H <sub>1</sub>	OD	B	B <sub>1</sub>	B <sub>2</sub>
	mm in.	90 3.54	66 2.60	18 0.71	AF 32	AF 32	M 24 × 1.5

## Blanking plug for pilot valves

**Figure 82:  
Blanking plug**

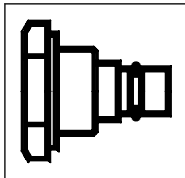

**Figure 83: Blanking plug**

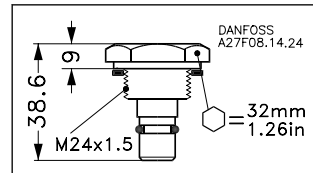

**Table 61: Blanking plug**

Description	Code no.
Blanking plug	027F1046

**Figure 84: FIA Straightway**

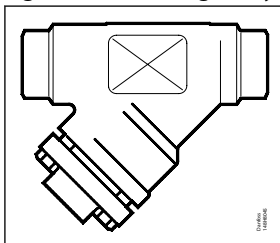

**Table 62: Recommended filters**

Recommended filters						Filter element for liquid line		Filter element for suction line	
						150 mesh	100 mesh	72 mesh	38 mesh
Filter Type	Size	D	A	FPT	SOC	100 my	150 my	250 my	500 my
FIA Straightway	20 (¾ in.)	148B5343	148B5347	148B5349	148B5348	148H3122	148H3124	148H3126	148H3128
FIA Straightway	25 (1 in.)	148B5443	148B5447	148B5449	148B5448	148H3123	148H3125	148H3127	148H3129
FIA Straightway	32 (1¼ in.)	148B5544	148B5552	148B5549	148B5548	148H3123	148H3125	148H3127	148H3129
FIA Straightway	40 (1½ in.)	148B5625	148B5644		148B5645	148H3123	148H3125	148H3127	148H3129
FIA Straightway	50 (2 in.)	148B5713	148B5716		148B5717	148H3157	148H3130	148H3138	148H3144
FIA Straightway	65 (2½ in.)	148B5813	148B5815				148H3131	148H3139	148H3145
FIA Straightway	80 (3 in.)	148B5906	148B5908				148H3119	148H3120	148H3121
FIA Straightway	100 (4 in.)	148B6007	148B6009				148H3132	148H3140	148H3146
FIA Straightway	125 (5 in.)	148B6106	148B6108				148H3133	148H3141	148H3147
FIA Straightway	150 (6 in.)	148B6203	148B6205				148H3134	148H3142	148H3148

## Certificates, declarations, and approvals

The list contains all certificates, declarations, and approvals for this product type. Individual code number may have some or all of these approvals, and certain local approvals may not appear on the list.

Some approvals may change over time. You can check the most current status at [danfoss.com](http://danfoss.com) or contact your local Danfoss representative if you have any questions.

**Table 63: The ICV valve approvals**

	<p>The ICV valve concept is designed to fulfill global refrigeration requirements. For specific approval information, please contact Danfoss.</p> <p>The ICS valves are approved in accordance with the European standard specified in the Pressure Equipment Directive and are CE marked.</p>
---	--

**Table 64: ICS valves**

ICS valves			
Nominal bore	DN ≤ 25 (1 in.)	DN 32-65 (1¼ - 2½ in.)	DN 80-125 (3 - 5 in.)
Classified for	Fluid group I		
Category	Article 3, paragraph 3	II	III

**Table 65: Certificates and declarations**

File name	Document type	Document topic	Approval authority
RU Д-ДК.БЛ08.В.00191_18	EAC Declaration	Machinery & Equipment	EAC
0045 202 1204 Z 00354 19 D 001(00)	Pressure - Safety Certificate	-	TÜV
RU Д-ДК.БЛ08.В.00189_18	EAC Declaration	EMC	EAC
RU Д-ДК.РА01.В.72054_20	EAC Declaration	PED	EAC
RU С-ДК.БЛ08.В.01093_20	Pressure - Safety Certificate	PED	EAC
033F0685.AK	EU Declaration	EMCD/PED	Danfoss
033F0691.AE	Manufacturers Declaration	RoHS	Danfoss
0045 202 1204 Z 00355 19 D 001(00)	Pressure - Safety Certificate	-	TÜV
19.10325.266	Marine - Safety Certificate	-	RMRS

## Online support

Danfoss offers a wide range of support along with our products, including digital product information, software, mobile apps, and expert guidance. See the possibilities below.

### The Danfoss Product Store



The Danfoss Product Store is your one-stop shop for everything product related—no matter where you are in the world or what area of the cooling industry you work in. Get quick access to essential information like product specs, code numbers, technical documentation, certifications, accessories, and more.

Start browsing at [store.danfoss.com](https://store.danfoss.com).

### Find technical documentation



Find the technical documentation you need to get your project up and running. Get direct access to our official collection of data sheets, certificates and declarations, manuals and guides, 3D models and drawings, case stories, brochures, and much more.

Start searching now at [www.danfoss.com/en/service-and-support/documentation](https://www.danfoss.com/en/service-and-support/documentation).

### Danfoss Learning



Danfoss Learning is a free online learning platform. It features courses and materials specifically designed to help engineers, installers, service technicians, and wholesalers better understand the products, applications, industry topics, and trends that will help you do your job better.

Create your Danfoss Learning account for free at [www.danfoss.com/en/service-and-support/learning](https://www.danfoss.com/en/service-and-support/learning).

### Get local information and support



Local Danfoss websites are the main sources for help and information about our company and products. Find product availability, get the latest regional news, or connect with a nearby expert—all in your own language.

Find your local Danfoss website here: [www.danfoss.com/en/choose-region](https://www.danfoss.com/en/choose-region).

### Spare Parts



Get access to the Danfoss spare parts and service kit catalog right from your smartphone. The app contains a wide range of components for air conditioning and refrigeration applications, such as valves, strainers, pressure switches, and sensors.

Download the Spare Parts app for free at [www.danfoss.com/en/service-and-support/downloads](https://www.danfoss.com/en/service-and-support/downloads).

### Coolselector®2 - find the best components for you HVAC/R system



Coolselector®2 makes it easy for engineers, consultants, and designers to find and order the best components for refrigeration and air conditioning systems. Run calculations based on your operating conditions and then choose the best setup for your system design.

Download Coolselector®2 for free at [coolselector.danfoss.com](https://coolselector.danfoss.com).

Danfoss can accept no responsibility for possible errors in catalogues, brochures and other printed material. Danfoss reserves the right to alter its products without notice. This also applies to products already on order provided that such alterations can be made without subsequential changes being necessary in specifications already agreed. All trademarks in this material are property of the respective companies. Danfoss and the Danfoss logotype are trademarks of Danfoss A/S. All rights reserved.