

Data Sheet

Safety relief valves
Type **BSV-8**

Used as pressure limiting devices to protect hydraulic systems and components



BSV is a standard, back pressure independent safety relief valve, especially designed for protection of small components against excessive pressure and as a pilot valve for the pilot operated internal safety valve, type POV.

BSV is an angle-way safety relief valve which can operate with a very high back pressure. The valve is designed to meet the strict quality demands and safety requirements for refrigeration installations, specified by the international classification societies.

As the valve is not dependent on the back pressure, it is recommended for use as an internal safety relief valve. However, the valve can also be used as an external safety relief valve. The spring housing is tightly sealed to avoid refrigerant leakage.

The inlet flow diameter of the BSV 8 is 8.0 mm (5/16 in.).

The valves can be delivered with set pressures between 10 and 25 bar (145 and 363 psig).

Standard pressure setting valves having "TÜV Pressure Setting Certificate" with each valve are also available.

Features:

- Classification: DNV, BV, EAC etc. To get an updated list of certification on the products please contact your [local Danfoss Sales Company](#).

Media

Refrigerants

Applicable for the refrigerants HCFC, HFC, R717 (Ammonia), R744 (CO₂). Flammable hydrocarbons are not recommended. For further information please contact your local Danfoss Sales Company.

New refrigerants

Danfoss products are continually evaluated for use with new refrigerants depending on market requirements.

When a refrigerant is approved for use by Danfoss, it is added to the relevant portfolio, and the R number of the refrigerant (e.g. R513A) will be added to the technical data of the code number. Therefore, products for specific refrigerants are best checked at store.danfoss.com/en/, or by contacting your local Danfoss representative.

Product specification

Design

BSV is designed as a standard safety relief valve (DIN 3320) which are recommended for refrigeration plants. On a rise in pressure above the set pressure, the safety relief valve will initially start opening slightly, to minimise the outlet of refrigerant. If the pressure continues to increase, the valve will open fully. The safety relief valve will be fully open before the pressure is 10% higher than set pressure, and fully closed before the pressure is 10% below set pressure.

The valve is recommended as an internal safety relief valve because its function is independent of the back pressure. The valve can also be used as an external safety relief valve.

Figure 1: Design

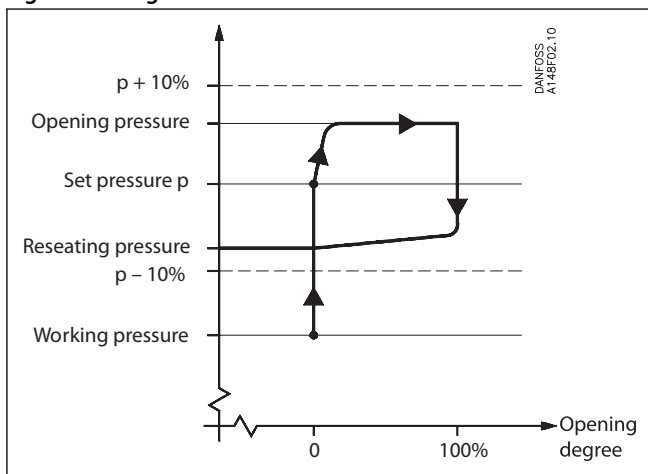

Pressure and temperature data

Pressure

Pressure setting range: 10 – 25 bar (145 – 363 psig), For further information please contact your [local Danfoss Sales Company](#).

The valves are designed for:

Strength test: 43 bar (624 psig)

Leakage safety: 25 bar (363 psig)

Special circumstances such as vibrations (which should be avoided) and oscillating pressure may require an increased difference between the operational pressure and the closing pressure.

Pressure setting

The operating pressure of the plant should be at least 15% below the set pressure. This allows a perfect re-seating of the safety relief valve after having been activated.

Temperature range for BSV used as an external safety relief valve:

-30 °C /+ 100 °C (-22 °F /+ 212 °F)

Temperature range for BSV used as a pilot valve for POV:

-50 °C /+ 100 °C (-58 °F /+ 212 °F)

NOTE:

For temperatures below -30 °C (-22 °F), the valve may not re-seat to a 100% gas tightness when activated.

Housing

Made of special steel approved for low temperature application. Spindle and seat are made of stainless steel, to ensure precise operation even during extraordinary conditions. The gasket of the valve cone is made of a special neoprene compound.

Material specification

Figure 2: BSV-8

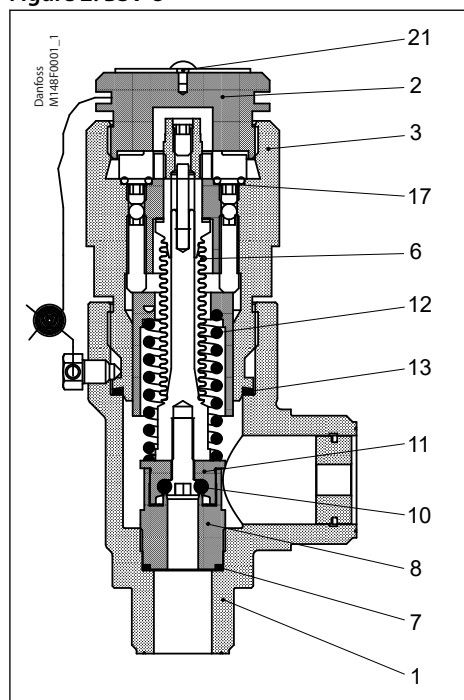

Table 1: Material specification

No.	Part	Material	DIN	ISO	ASTM
1	Housing	Steel	TT St 35 N/V, 17173	TW 6, 2604/3-75	Grade 1, A333, A334 A350 LF2 ⁽¹⁾
2	Threaded plug	Steel	9S Mn28 1651 - 88	11S Mn28 630/9 - 88	1213 SAE J 403
3	Valve top	Steel	St. 37.2, 1652 - 2 - 90	Fe 360 B, 660 - 80	Grade C, A 283
6	Bellow	Stainless steel			
7	Gasket	Aluminium			
8	Valve seat	Stainless steel			
10	O-ring	Cloroprene (Neoprene)			
11	Valve cone	Steel			
12	Spring	Steel	Class C, 17223-1-84		A 679SAE J 403
13	O-ring	Cloroprene (Neoprene)			
17	Gasket	Aluminium			
21	Marking label	Aluminium			

⁽¹⁾ Alternative material

Installation

To ensure exact operation of the safety relief valve it should be installed with the spring housing upwards. If the valve is mounted as an internal safety relief valve without any demand for exact opening pressure, the valve may be fitted with the spring housing in other positions. When the valve is mounted, it is important to avoid the influence of static, dynamic and thermal stress.

A very precise technique has been applied for the production of the seal. However, this seal can still be damaged, if dirt is blown from the pipe system into the valve.

Re-calibration/servicing

In certain countries the authorities demand that the valves are checked at least once a year (see local rules).

Control/Identification

After adjustment of the set pressure at Danfoss, the valves are sealed. For that reason Danfoss can only guarantee correct operation, as long as the seal remains unbroken.

All valves are provided with a metal plate with the following information:

- Flow diameter
- Set pressure
- Date of production
- Production number
- Type approved code

Transport/Handling

The valves are fitted with special protection covers and packed in purpose made transportation cartons. It is important that the cover remains fitted around the valve until it is installed.

NOTE:

To ensure the exact and precise operation of the valve it must be handled with care.

Connections

Available with the following connections:

Outside pipe thread T (ISO 228/1)

Figure 3: Connections T

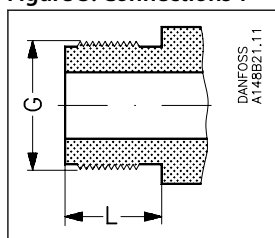

Table 2: T outside pipe thread, (ISO 228/1)

Size mm	Size in.	Inlet	Outlet	L [mm]	L [in.]
8	5/16	G 3/4	G 1	17	0.67

Capacity

The design and construction of the safety relief valve has been tested and approved by TÜV. This test comprises control of the function of the valve as well as measuring of the capacity, which is the basis of the curves and tables on the following pages. The values in the table are based on saturated gas.

If e.g. back pressure or superheated gas have to be taken into consideration, the formulas or the Danfoss computation program Coolselector can be used.

Table 3: Capacity

Valve	Nominal size		Flow diameter	Flow area	De-rated, certified coefficient of discharge
	Inlet	Outlet	d_o	A_o	
BSV 8	15 mm	20 mm	8 mm	50 mm ²	0.46
	1/2 in.	3/4 in.	0.315 in.	0.078 in ²	

NOTE:

The discharge capacity of the safety relief valves are based on (ISO 4126-1/EN 1268-1 / prEN 1313 6 (1998)).

Table 4: Discharge capacity

$q_m = 0.2883 \times C \times A_o \times K_{dr} \times K_b \times \sqrt{p/v}$	
q_m	Discharge capacity (kg/h)
C	Discharge function depending of the actual refrigerant (k) see table 2.
A_o	Flow area of the safety relief valve (mm ²).

Safety relief valves, Type BSV-8

$$q_m = 0.2883 \times C \times A_0 \times K_{dr} \times K_b \times \sqrt{p/v}$$

K_{dr}	De-rated coefficient of discharge ($K_{dr} = K_d \times 0.9$), (the K_{dr} is certified by TÜV) see table 1.
K_b	Correction factor for sub-critical flow. (-) $K_b = 1.0$ when the back pressure is lower than approx. $0.5 \times$ relieving pressure ($P_b < 0.5 \times p$).
v	Specific volume of the vapour. (m ³ /kg)
P_{set}	Set pressure, the predetermined pressure at which a pressure relief valve under operation starts to open (p_{set} is indicated on the metal plate on the safety relief valve). (bar g)
P_{atm}	Atmospheric pressure. (1 bar)
p	Relieving pressure, $p = p_{set} \times 1.1 + P_{atm}$ (bar a)

NOTE:

For back pressure higher than $0.5 \times p$, the Danfoss computer program Coolselector or the above mentioned standard must be used when calculating the capacity.

Table 5: Properties of Refrigerants

Refrigerant	Isentropic exponent [κ]	Discharge function [C]
R22	1.17	2.54
R134a	1.12	2.5
R404A	1.12	2.49
R410A	1.17	2.54
R717 (Ammonia)	1.31	2.64
R744 (CO ₂)	1.3	2.63
Air	1.4	2.7

Figure 4: BSV 8, back pressure = atmosphere pressure

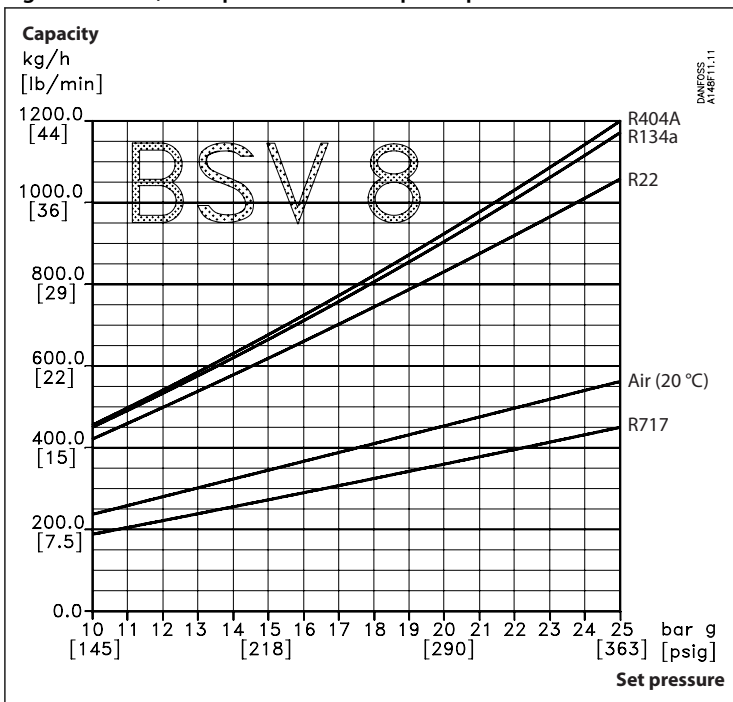

Table 6: BSV 8, back pressure = atmosphere pressure

Set pressure		R22	R134a	R404A	R717	Air (20 °C)
13 barg	kg/h	540	575	590	240	300
189 psig	lb/min	19.9	21.2	21.6	8.7	11.1
18 barg	kg/h	745	810	825	325	410
261 psig	lb/min	27.5	29.7	30.3	11.9	15
21 barg	kg/h	875	955	970	375	475
305 psig	lb/min	32.2	35.1	35.7	13.8	17.4
25 barg	kg/h	1060	1175	1200	445	560
363 psig	lb/min	38.9	43.2	44	16.4	20.6

Safety relief valves, Type BSV-8

NOTE:

The capacity calculation is based on ISO 4126 - 1 / EN 1268 - 1 / prEN 13136 (1998).

Figure 5: BSV 8, back pressure = 0.6 × set pressure (barg/psig)

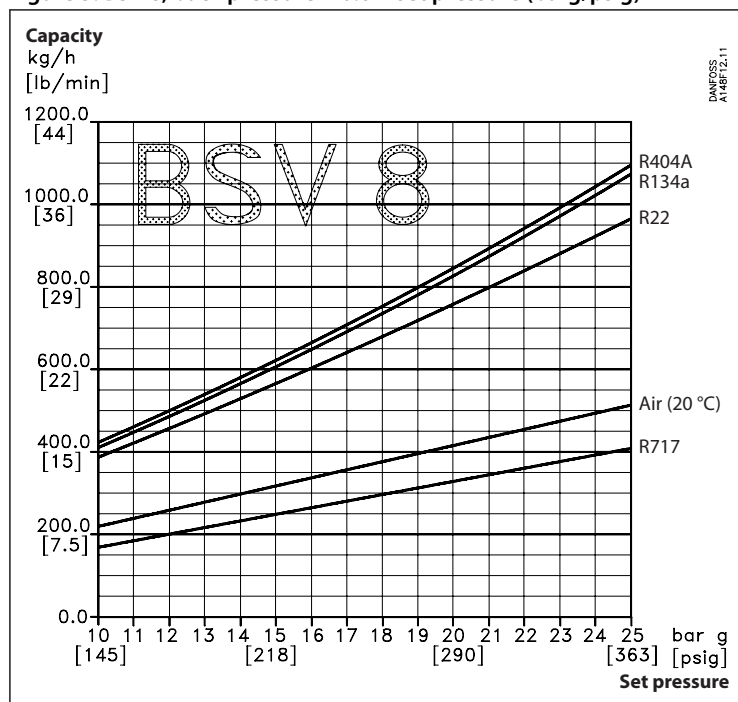

Table 7: BSV 8, back pressure = 0.6 × set pressure (barg/psig)

Set pressure		R22	R134a	R404A	R717	Air (20 °C)
13 barg	kg/h	495	525	535	215	275
189 psig	lb/min	18.2	19.4	19.7	8	10.1
18 barg	kg/h	680	740	755	295	375
261 psig	lb/min	25.1	27.1	27.7	10.9	13.7
21 barg	kg/h	800	875	885	345	435
305 psig	lb/min	29.4	32.1	32.6	12.6	15.9
25 barg	kg/h	965	1075	1095	410	510
363 psig	lb/min	35.5	39.4	40.2	15	18.8

NOTE:

The capacity calculation is based on ISO 4126 - 1 / EN 1268 - 1 / prEN 13136 (1998).

Dimensions and weight

Figure 6: BSV 8

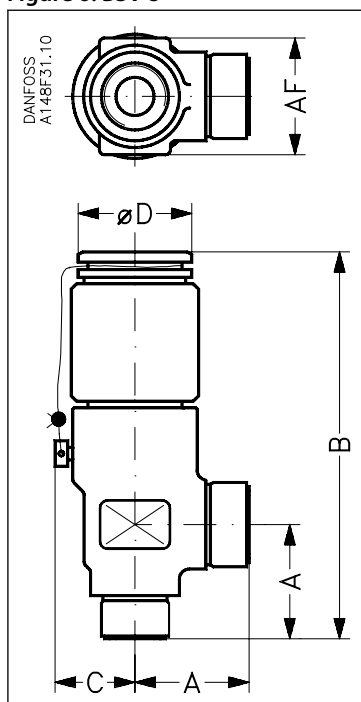

Table 8: BSV 8, with threaded connections ISO 228/1 pipe threads

Valve size		A	B	C	∅D	AF	Weight
BSV 8 (5/16 in.)	mm	45	150	32	50	46	1.5 kg
	in.	1.77	5.91	1.26	1.97	1.81	3.3 lb

NOTE:

Specified weights are approximate values only.

Ordering

How to order

The table below is used to identify the valve required.

Please note that the type codes only serve to identify the valves, some of which may not form part of the standard product range. For further information please contact your local Danfoss Sales Company.

Table 9: Example for type codes

BSV	8	T	211
-----	---	---	-----

Table 10: Type codes

Valve type	BSV	Back pressure independent safety valve	
Nominal size in mm	8	DN 8	
Connections	T	Outside threaded connections: ISO 228/1 Pipe thread Fittings for connections must be ordered seperately Fittings for pilot operation The welding fittings for single mounted safety relief valve must be ordered seperately	
Pressure setting	Standard pressure setting: 2xx		
	210	10 barg (145 psig)	
	211	11 barg (160 psig)	
	212	12 barg (174 psig)	
	213	13 barg (189 psig)	
	214	14 barg (203 psig)	
	215	15 barg (218 psig)	
	216	16 barg (232 psig)	
	217	17 barg (247 psig)	
	218	18 barg (261 psig)	
	219	19 barg (276 psig)	
	220	20 barg (290 psig)	
	221	21 barg (305 psig)	
	222	22 barg (319 psig)	
	223	23 barg (334 psig)	
	224	24 barg (348 psig)	
	225	25 barg (363 psig)	
		Standard pressure setting with TÜV certificate: 3xx	
	310	10 barg (145 psig)	
	311	11 barg (160 psig)	
	312	12 barg (174 psig)	
	313	13 barg (188 psig)	
	314	14 barg (203 psig)	
	315	15 barg (218 psig)	
	316	16 barg (232 psig)	
	317	17 barg (247 psig)	
	318	18 barg (261 psig)	
	319	19 barg (276 psig)	
	320	20 barg (290 psig)	
	321	21 barg (304 psig)	
	322	22 barg (319 psig)	
	323	23 barg (334 psig)	
324	24 barg (348 psig)		
325	25 barg (362 psig)		

NOTE:

Where products need to be certified according to specific certification societies, the relevant information should be included at the time of order.

Certified BSV valves with standard set pressure

Table 11: Certified BSV valves with standard set pressure

Size		Construction and test facilities are approved by TÜV		
mm	in.	Type	barg (psig)	Part No.
8	5/16	BSV8 T 210	10 (145)	2416+200
8	5/16	BSV8 T 211	11 (160)	2416+309
8	5/16	BSV8 T 212	12 (174)	2416+310
8	5/16	BSV8 T 213	13 (189)	2416+201
8	5/16	BSV8 T 214	14 (203)	2416+311
8	5/16	BSV8 T 215	15 (218)	2416+312
8	5/16	BSV8 T 216	16 (232)	2416+221
8	5/16	BSV8 T 217	17 (247)	2416+313
8	5/16	BSV8 T 218	18 (261)	2416+202
8	5/16	BSV8 T 219	19 (276)	2416+225
8	5/16	BSV8 T 220	20 (290)	2416+203
8	5/16	BSV8 T 221	21 (305)	2416+204
8	5/16	BSV8 T 222	22 (319)	2416+224
8	5/16	BSV8 T 223	23 (334)	2416+314
8	5/16	BSV8 T 224	24 (348)	2416+315
8	5/16	BSV8 T 225	25 (363)	2416+205

Certified BSV valves with standard set pressure and TÜV pressure setting certificate with each valve

Table 12: Certified BSV valves with standard set pressure and TÜV pressure setting certificate with each valve

Size		Each valve is certified by a representative from TÜV		
mm	in.	Type	barg (psig)	Part No.
8	5/16	BSV8 T 310	10 (145)	2416+316
8	5/16	BSV8 T 311	11 (160)	2416+317
8	5/16	BSV8 T 312	12 (174)	2416+318
8	5/16	BSV8 T 313	13 (189)	2416+206
8	5/16	BSV8 T 314	14 (203)	2416+319
8	5/16	BSV8 T 315	15 (218)	2416+320
8	5/16	BSV8 T 316	16 (232)	2416+222
8	5/16	BSV8 T 317	17 (247)	2416+321
8	5/16	BSV8 T 318	18 (261)	2416+207
8	5/16	BSV8 T 319	19 (276)	2416+322
8	5/16	BSV8 T 320	20 (290)	2416+208
8	5/16	BSV8 T 321	21 (305)	2416+209
8	5/16	BSV8 T 322	22 (319)	2416+210
8	5/16	BSV8 T 323	23 (334)	2416+323
8	5/16	BSV8 T 324	24 (348)	2416+324
8	5/16	BSV8 T 325	25 (363)	2416+211

Nipples and gaskets

Table 13: Attention: Fittings for connections must be ordered separately

Type	Code number
For stand-alone SFV 15/ SFA 15/ BSV-8: Nipples + gaskets set	148F3019
For system POV + BSV: Nipples + gaskets set	148H3453

Certificates, declarations, and approvals

The list contains all certificates, declarations, and approvals for this product type. Individual code number may have some or all of these approvals, and certain local approvals may not appear on the list.

Some approvals may change over time. You can check the most current status at danfoss.com or contact your local Danfoss representative if you have any questions.

Table 14: Valid approvals

Type	File name	Document type	Document topic	Approval authority
BSV	EAC RU Д-ДК.БЛ08.В.03706	EAC Declaration	Machinery & Equipment	
	TÜV 0045 202 1204 Z 00354 19 D 001(00)	Pressure - Safety Certificate		
	EAC RU C-ДК.БЛ08.В.01096_20	Pressure - Safety Certificate	PED	
	033F0473.AD	Manufacturers Declaration	ATEX	Danfoss
	EU 033F0685.AK	EU Declaration	EMCD/PED	Danfoss
BSV 8	BV 39409-B0 BV	Marine - Safety Certificate		
	DNV GL TAP000000M	Marine - Safety Certificate		
	TUV SV 17-1013	Pressure - Safety Certificate		
	RMRS 19.10327.266	Marine - Safety Certificate		

Table 15: Pressure Equipment Directive (PED)

	The BSV-valves are approved in accordance with the European standard specified in the Pressure Equipment Directive and are CE marked. For further details / restrictions - see Installation guide.
---	--

Table 16: Compliance

Type	BSV 8
Nominal bore	8 mm (0.315 in.)
Classified for	Fluid group I
Category	IV

Online support

Danfoss offers a wide range of support along with our products, including digital product information, software, mobile apps, and expert guidance. See the possibilities below.

The Danfoss Product Store



The Danfoss Product Store is your one-stop shop for everything product related—no matter where you are in the world or what area of the cooling industry you work in. Get quick access to essential information like product specs, code numbers, technical documentation, certifications, accessories, and more.

Start browsing at store.danfoss.com.

Find technical documentation



Find the technical documentation you need to get your project up and running. Get direct access to our official collection of data sheets, certificates and declarations, manuals and guides, 3D models and drawings, case stories, brochures, and much more.

Start searching now at www.danfoss.com/en/service-and-support/documentation.

Danfoss Learning



Danfoss Learning is a free online learning platform. It features courses and materials specifically designed to help engineers, installers, service technicians, and wholesalers better understand the products, applications, industry topics, and trends that will help you do your job better.

Create your Danfoss Learning account for free at www.danfoss.com/en/service-and-support/learning.

Get local information and support



Local Danfoss websites are the main sources for help and information about our company and products. Find product availability, get the latest regional news, or connect with a nearby expert—all in your own language.

Find your local Danfoss website here: www.danfoss.com/en/choose-region.

Spare Parts



Get access to the Danfoss spare parts and service kit catalog right from your smartphone. The app contains a wide range of components for air conditioning and refrigeration applications, such as valves, strainers, pressure switches, and sensors.

Download the Spare Parts app for free at www.danfoss.com/en/service-and-support/downloads.

Coolselector®2 - find the best components for you HVAC/R system



Coolselector®2 makes it easy for engineers, consultants, and designers to find and order the best components for refrigeration and air conditioning systems. Run calculations based on your operating conditions and then choose the best setup for your system design.

Download Coolselector®2 for free at coolselector.danfoss.com.

Danfoss can accept no responsibility for possible errors in catalogues, brochures and other printed material. Danfoss reserves the right to alter its products without notice. This also applies to products already on order provided that such alterations can be made without subsequential changes being necessary in specifications already agreed. All trademarks in this material are property of the respective companies. Danfoss and the Danfoss logotype are trademarks of Danfoss A/S. All rights reserved.